

MONS

LKZ 42416

52

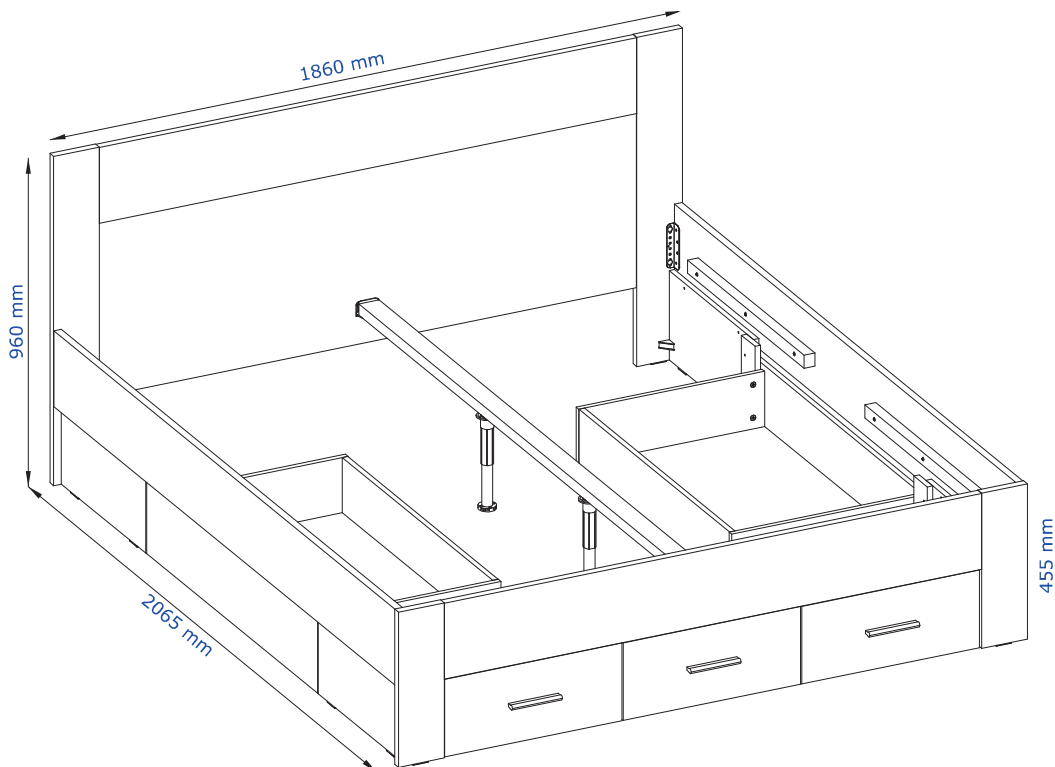

- | | | |
|---|---|--|
| D Montageanleitung
Bett >Mons< | GB Assembly instructions
Bed >Mons< | SRB Упутства за инсталацију
Бед >Mons< |
| FR Notice de montage
Lit >Mons< | IT Istruzioni di montaggio
Letto >Mons< | HR Upute za instalaciju
Krevet >Mons< |
| NL Handleiding voor de montage
Bed >Mons< | PL Instrukcja montażu
Łóżko >Mons< | SL Návod na montaž
Postelja >Mons< |
| CZ Montážní návod
Postel >Mons< | SK Návod na montáž
Posteľ >Mons< | LT Surinkimo instrukcijos
Gulta >Mons< |
| HU Szerelési útmutató
Ágy >Mons< | RO Instrucțiuni de montaj
Pat >Mons< | LV Montāžas instrukcija
Lova >Mons< |
| TR Montaj talimatı
Yatak >Mons< | RU Инструкция по монтажу
Кровать >Mons< | EE Kokkupaneku juhised
Voodi >Mons< |
| ES Instrucciones de montaje
Cama >Mons< | PT Instruções de montagem
Cama >Mons< | |

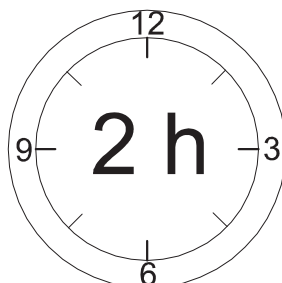
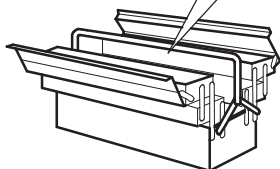
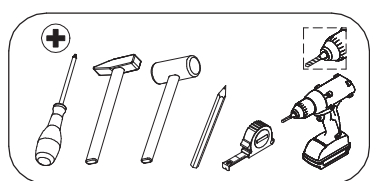
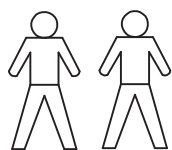

* 2 8 1 1 9 9 *

V-2026.01.20

MONS 52

D-Ziehen Sie alle Schrauben sowie tragende Verbindungsteile nach ca. 5 Wochen nach, um eine dauerhafte Standsicherheit zu gewährleisten.

GB-After approx. 5 weeks, tighten all screws and load-bearing connecting parts to ensure permanent stability.

FR-Resserrez toutes les vis ainsi que les pièces de fixation au bout d'environ 5 semaines pour garantir une sécurité de fixation durable.

IT- Ristringere tutte le viti e giunture dopo ca. 5 settimane, al fine di garantire una durevole solidità.

NL-Draai alle schroeven en ook dragende verbindingstukken na ca. 5 weken nog eens vast, zodat een continue stabiliteit wordt gegarandeerd.

PL-Prosimy po ok. 5 tygodniach dokręcić wszystkie śruby i elementy łączeniowe. Zagwarantuje to Państwu trwałość i stabilność połączeń.

CZ- Dotáhněte všechny šrouby a nosné spojovací díly přibližně po 5 týdnech, aby se zaručila trvalá stabilita.

SK-Po cca 5 týždňoch dotiahnite skrutky, aby bola zaručená ich trvalá stabilita.

HU-Húzza utána - kb. 5 hét múlva - az összes csavart és a teherhordó összekötő-alkatrészeket abiztonság érdekében.

RO-Pentru a asigura o stabilitate de durată, strângeți după cca. 5 săptămâni toate șuruburile, precum și toate elementele portante de legătură.

TR-Tüm vida ve taşıyıcı bağlantı parçalarını kalıcı bir duruş güvenliğini sağlamak için yaklaşık 5 haftasonra tekrar sıkınız.

RU - Подкрутите все болты, а также несущие соединительные детали прикл. через 5 недель для обеспечения устойчивости в течение длительного времени.

SRB - Molim vas posle akroksa. 5 nedelja zategnite sve šrafove i pričvršćivače. To ће вам гарантовати трајност и стабилност веза.

HR - Molim vas, nakon cca. 5 tjedana zategnite sve vijke i pričvršćivače. To će vam jamčiti trajnost i stabilnost priključaka.

SL - Pýtame sa po cca. 5 týždňov utiahnite všetky skrutky a upevňovacie prvky. To zaručuje trvanlivosť a stabilitu spojov.

LT - Mes prašome po maždaug. 5 savaites priveržkite visus varžtus ir tvirtinimo detales. Taip užtikrinamas jungčių patvarumas ir stabilumas.

LV - Mēs lūdzam pēc apm. 5 nedēļas, pievelciet visas skrūves un stiprinājumus. Tas garantē savienojumu izturību un stabilitāti.

EE - Küsime pärast ca. 5 nädalat, pingutage kõiki kruvisid ja kinnitusi. See tagab ühenduste vastupidavuse ja stabiilsuse.

ES - Apriete todos los tornillos y elementos de conexión después de aprox. 5 semanas. Esto le garantizará la durabilidad y estabilidad de sus conexiones.

PT - Aperte todos os parafusos e elementos de ligação após aprox. 5 semanas. Isto garantirá a durabilidade e a estabilidade das suas ligações.

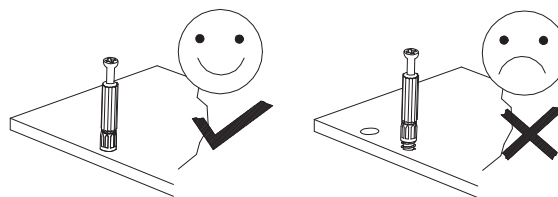

D Bitte nur mit einem Staubtuch oder leicht feuchtem Lappen reinigen. Keine scheuernden Putzmittel verwenden.

GB Please only clean with a duster or a damp cloth. Do not use any abrasive cleaners.

FR Veuillez nettoyer uniquement avec un chiffon à poussière ou un chiffon légèrement humide. Ne pas utiliser de détergent abrasif.

IT Si raccomanda di pulire solo con un panno per la polvere o uno strofinaccio umido. Non utilizzare detersivi abrasivi.

NL Reinig alleen met een stofdoek of een lichtjes vochtige doek. Gebruik geen schurende poetsmiddelen.

PL Czyszczenie należy wykonać wyłącznie za pomocą ściereczki lub lekko nawilżonego ręcznika. Nie stosować środków czyszczących do szorowania.

CZ Čistěte prosím jen prachovkou nebo lehce navlhčeným hadrem. Nepoužívejte drhňoucí čisticí prostředky.

SK Na čistenie používajte len prachovku alebo zľahka navlhčenú utierku. Nepoužívajte žiadne drhňúce čistiace prostriedky.

HU Kérjük, csak portórlő kendővel vagy enyhén nedves ronggyal tisztítsa. Ne használjon dörzshatású tisztítószer.

RO Vă rugăm să utilizați la curățare exclusiv o cârpă de șters praful sau o cârpă ușor umezită. Nu utilizați substanțe de curățat abrazive.

TR Lütfen sadece bir toz beziyle veya hafif nemli yumuşak bir bezle siliniz. Aşındırıcı temizlik malze-meleri kullanmayınız.

RU Для чистки используйте, пожалуйста, тряпку для пыли или слегка влажную ветошь. Не использовать абразивные чистящие средства.

SBR Чишћење треба обавити само крпом или благо влажним пешкиром. Немојте користити средство за чишћење рибања.

HR Čišćenje treba obaviti samo krpom ili blago navlaženim ručnikom. Ne koristite sredstva za čišćenje ribanja.

SL Čistenie by sa malo vykonávať len handričkou alebo ľahko navlhčeným uterákom. Nepoužívajte čistiace prostriedky na drhnutie.

LT Valyti galima tik šluoste arba lengvai sudrėkintu rankšluosčiu. Nenaudokite šveičiamųjų valiklių.

LV Tīršana jāveic tikai ar drānu vai viegli samitrinātu dvieli. Neizmantojiet tīršanas līdzekļus.

EE Puhastada tohib ainult lapiga või kergelt niisutatud rätikuga. Ärge kasutage puhastusvahendeid.

PT A limpeza deve ser feita apenas com um pano ou toalha ligeiramente húmida. Não utilize produtos de limpeza abrasivos.

ES La limpieza debe realizarse únicamente con un paño o toalla ligeramente húmedo. No utilice agentes de limpieza abrasivos.

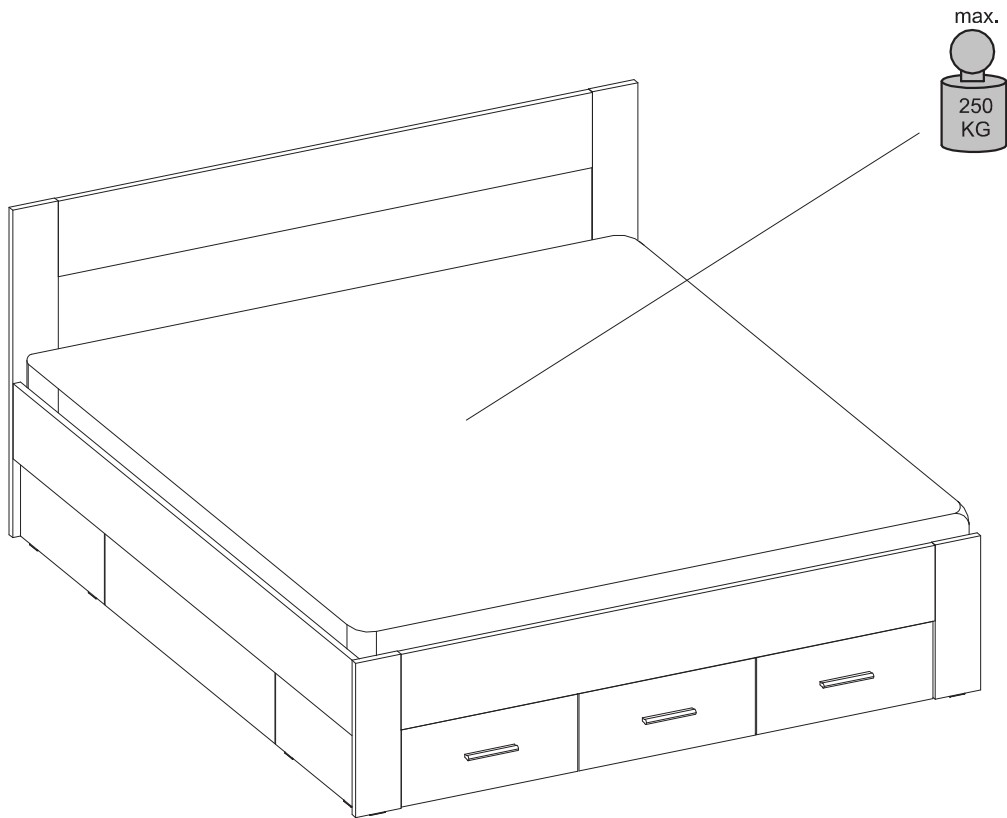
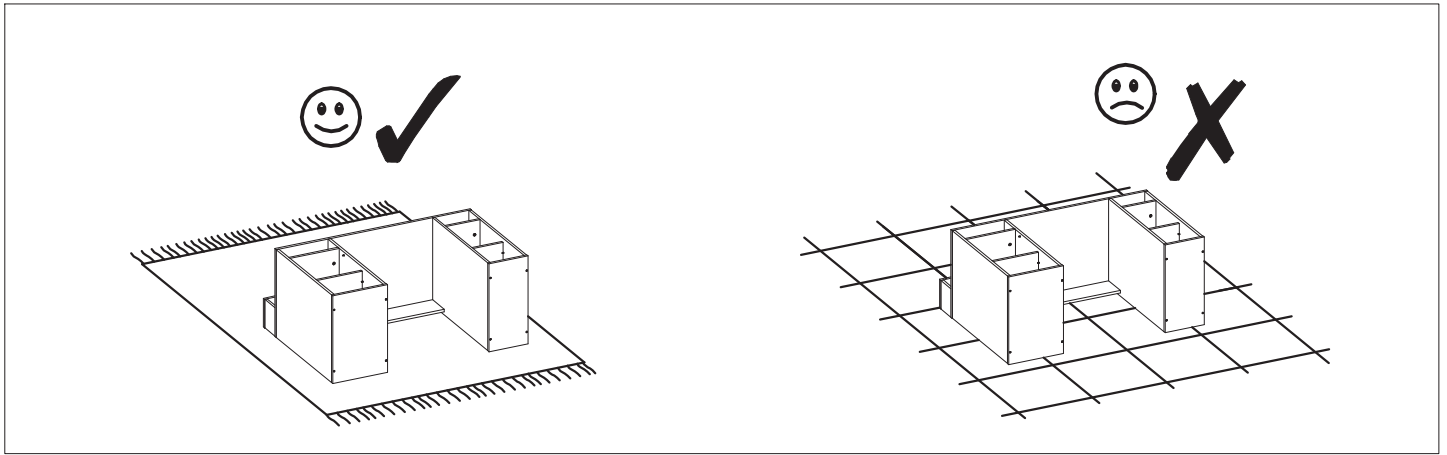
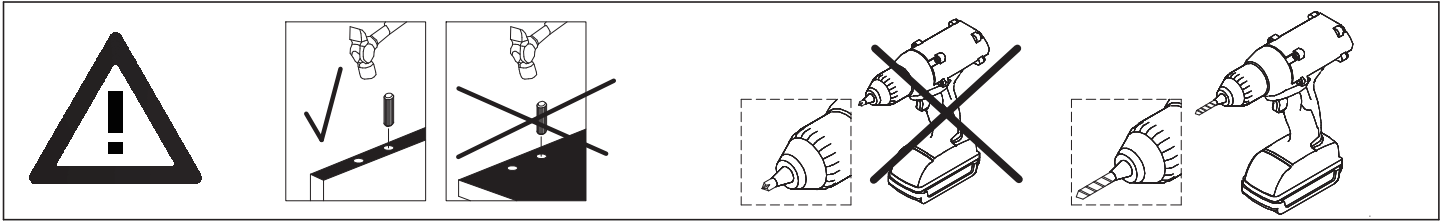
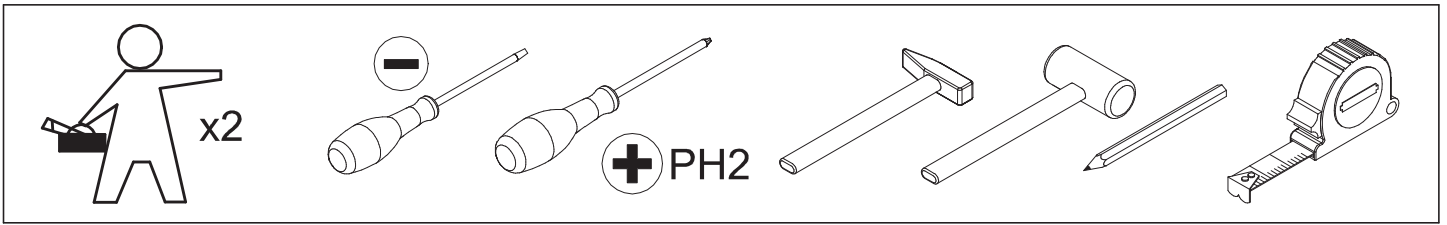

Service · Assistenza · Dienstverlening · Serwis Servis · Szerviz · Сервисная служба · Сервис · Serwis · Servis

Name · Nom · Nome · Naam · Nazwa · Jméno · Názov · Név · Denumire · Isim · Название	Mons
Тур · Туре · Tip · Típus · Tipo · Тип	52

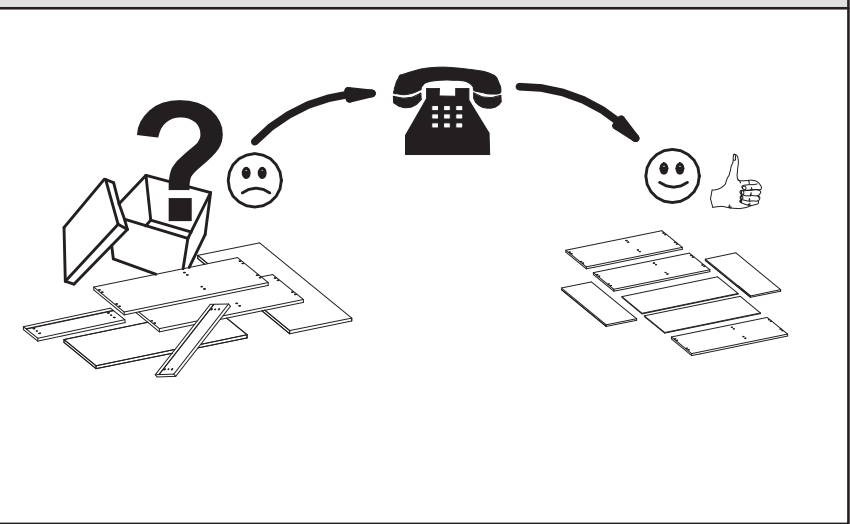
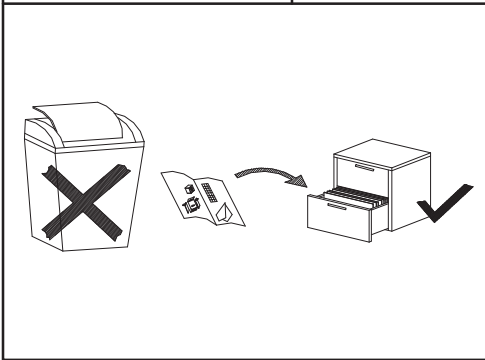

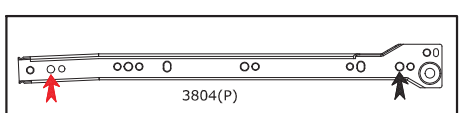
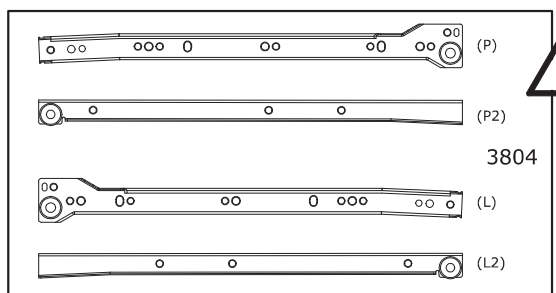

A Ø10x35 mm x8 3992	B Ø8x30 mm x34 3989	B1 Ø8x50 mm x12 3991	C Ø6,5x36,5 mm x20 4066	D Ø6,5x59 mm x14 4058
E Ø15x12 mm x26 3996	E1 Ø15x17 mm x22 3997	F Ø20 mm x20 136239	G Ø4,0x25 mm x6 145556	G1 Ø4,0x25 mm x44 3892
G2 Ø4,0x50 mm x12 81980	H Ø3,5x16 mm x90 3918	J Ø6,0x8 mm x8 213454	J1 Ø6,0x13 mm x28 3877	K Ø6,4x50 mm x36 3884
L 4 mm x1 3984	M 45x15x5 mm x20 90907	N 30x30x18 mm x10 79844	O 69x40x7 mm x2 4009	O1 69x39x32 mm x2 4077
P L-130/230 mm x2 4012	P1 L-70 mm x2	R 128x30x23 mm x4 210474	S L-128/D-148 mm x3 84110	T Ø 15 mm x8 3318
U L-350mm x3 3804				

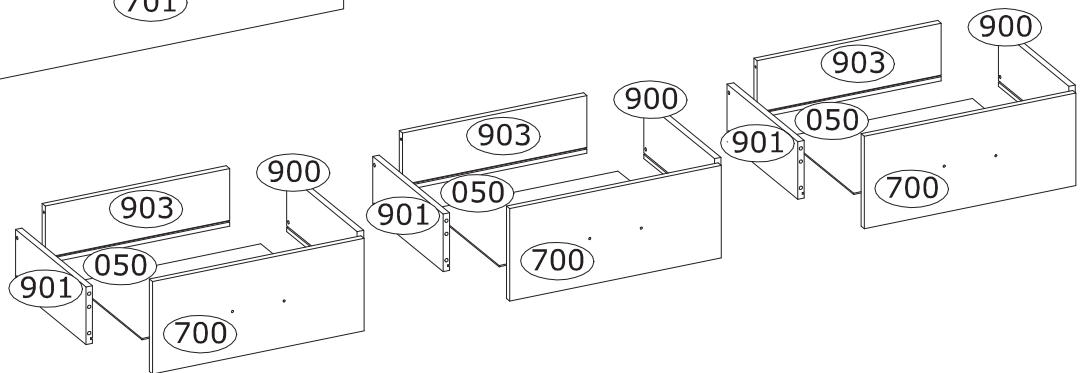
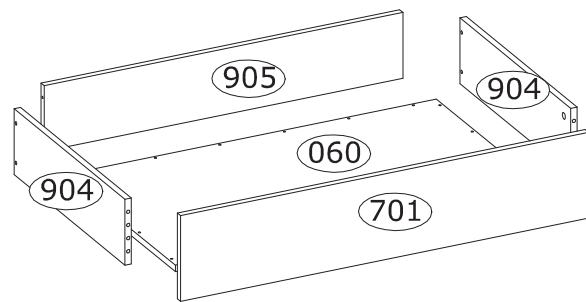
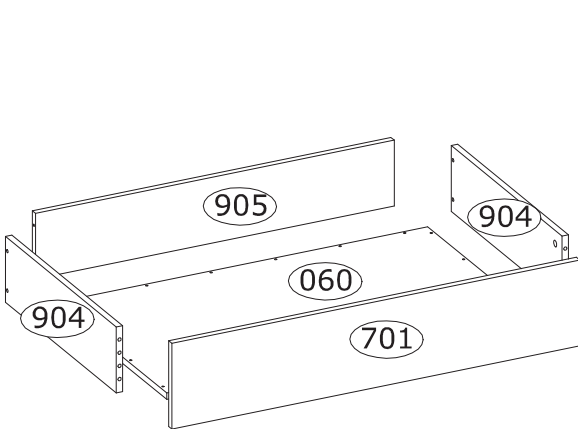
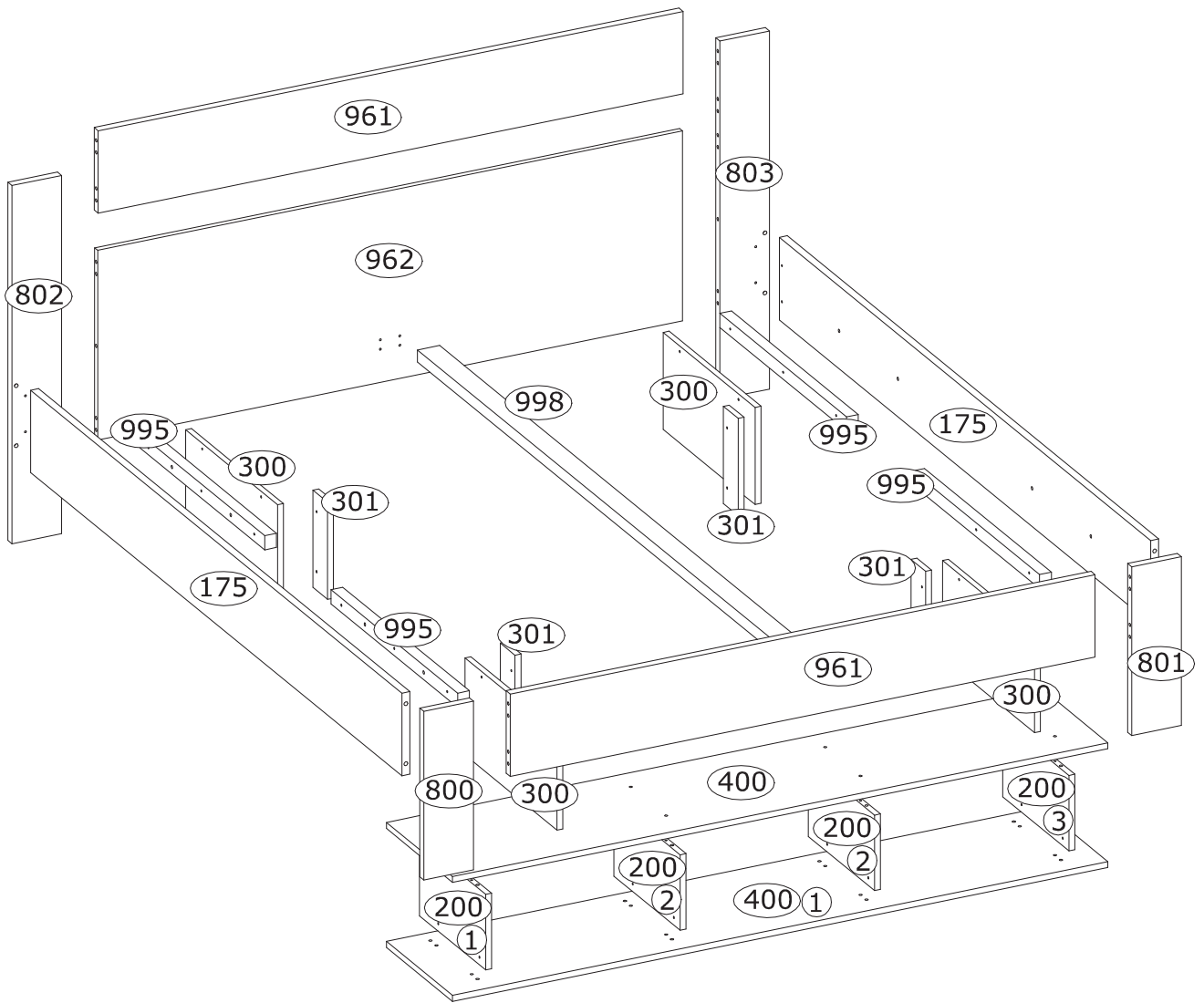

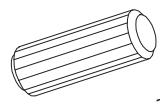
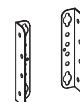

1

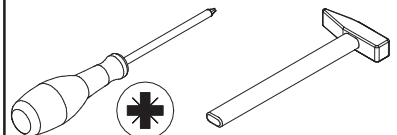
A Ø10x35 mm  x8 249428	R 128x30x23 mm  x4 210474	H Ø3,5x16 mm  x8 3918	J1 Ø6,0x13 mm  x8 3877	
---	--	--	---	--

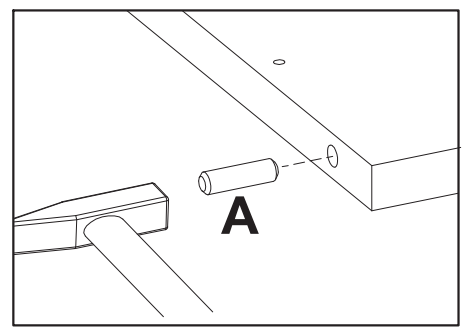
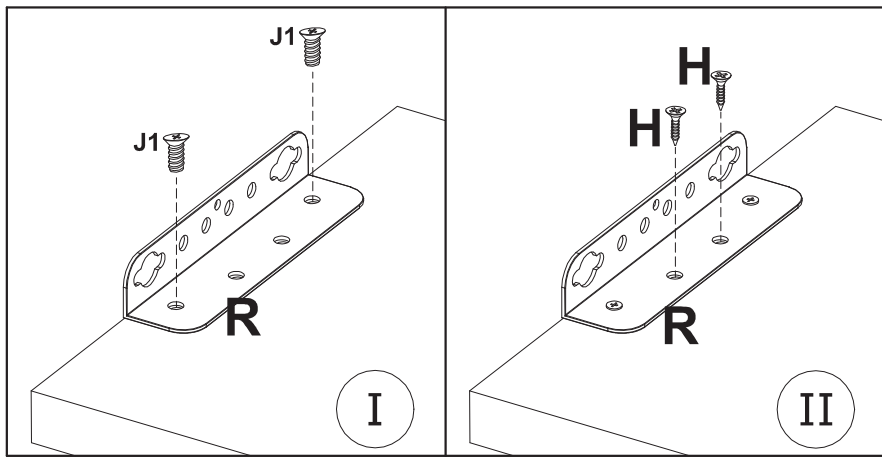
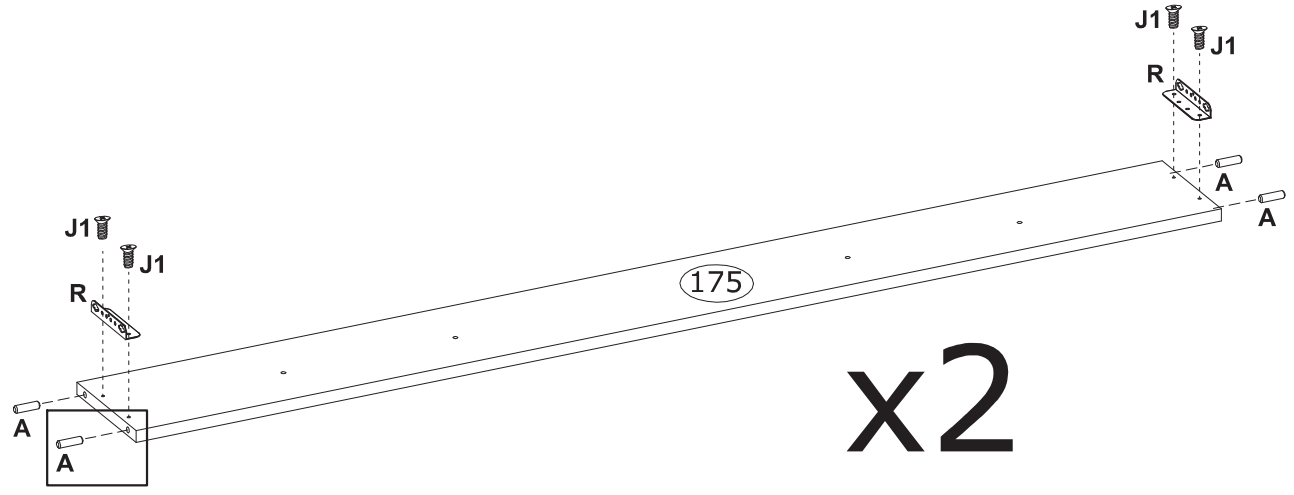

2

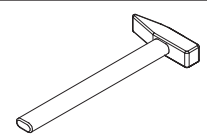
M 45x15x5 mm  x2 90907	
--	---

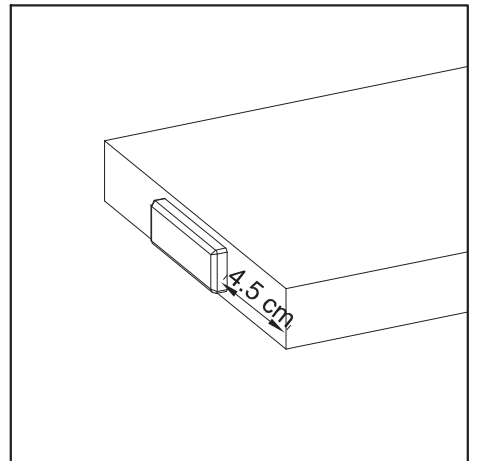
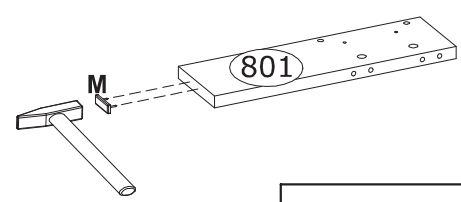
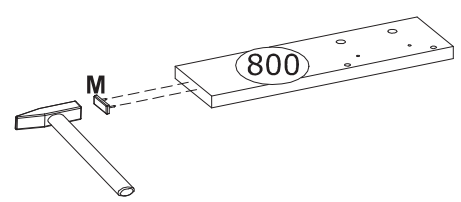

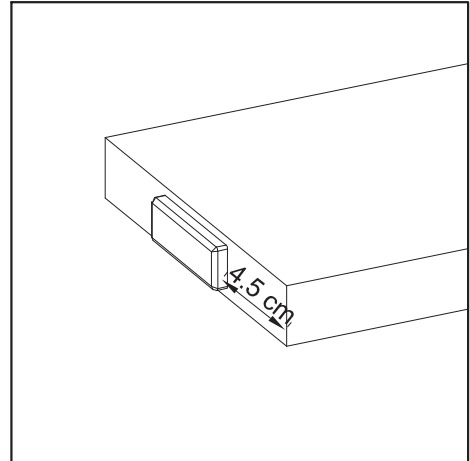
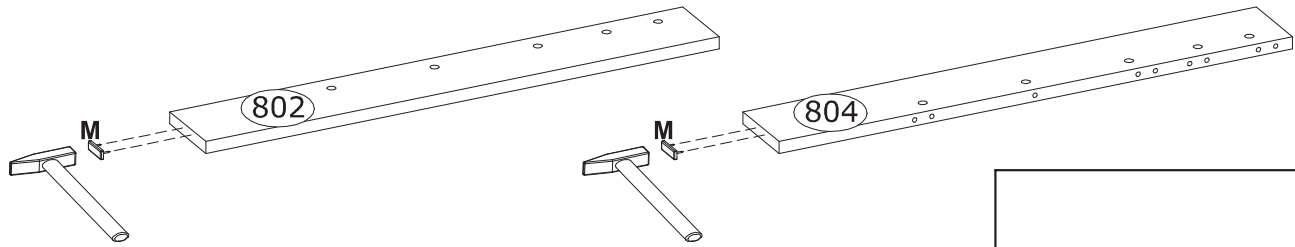
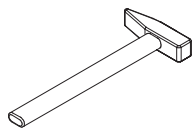

3

M 45x15x5 mm
x2
90907



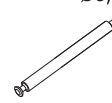

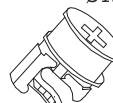
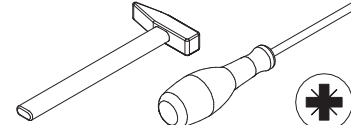
4

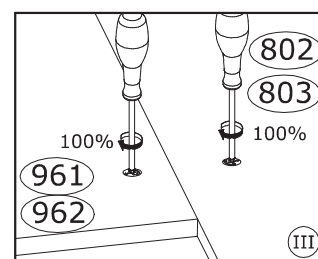
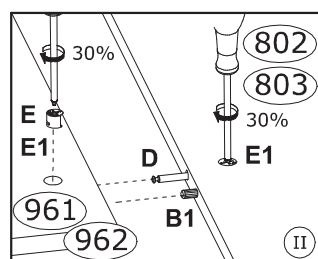
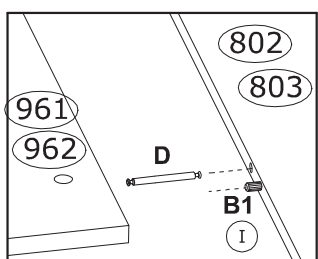
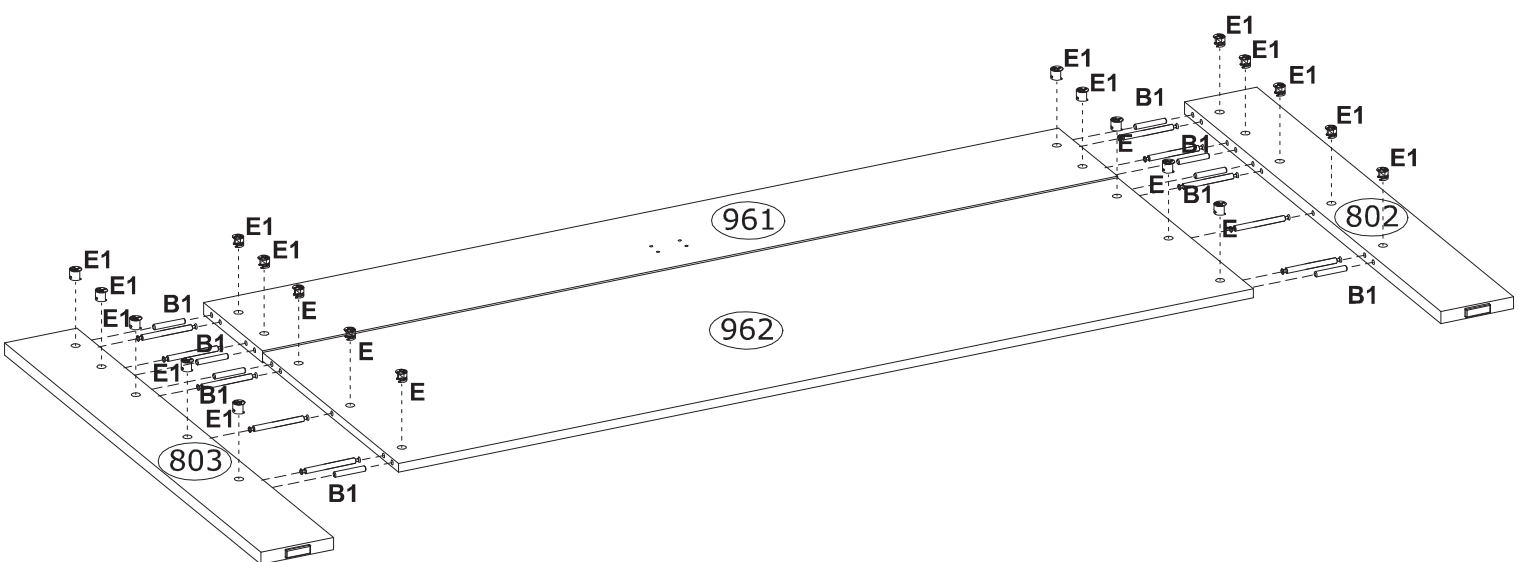
<p>B1 Ø8x50 mm x8 3991</p> 	<p>D Ø6,5x59 mm x10 4058</p> 	<p>E Ø15x12 mm x6 3996</p> 	<p>E1 Ø15x17 mm x14 3997</p> 	
--	--	--	---	---



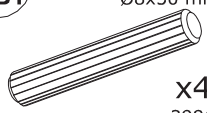
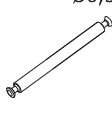
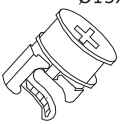

5

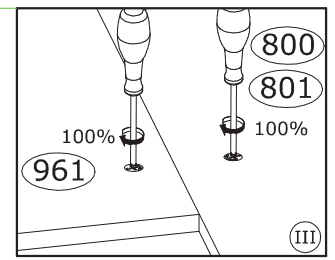
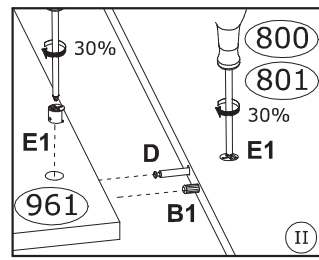
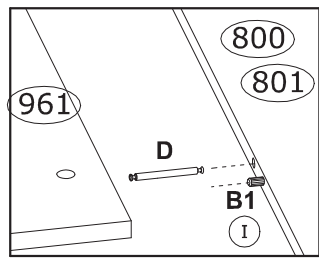
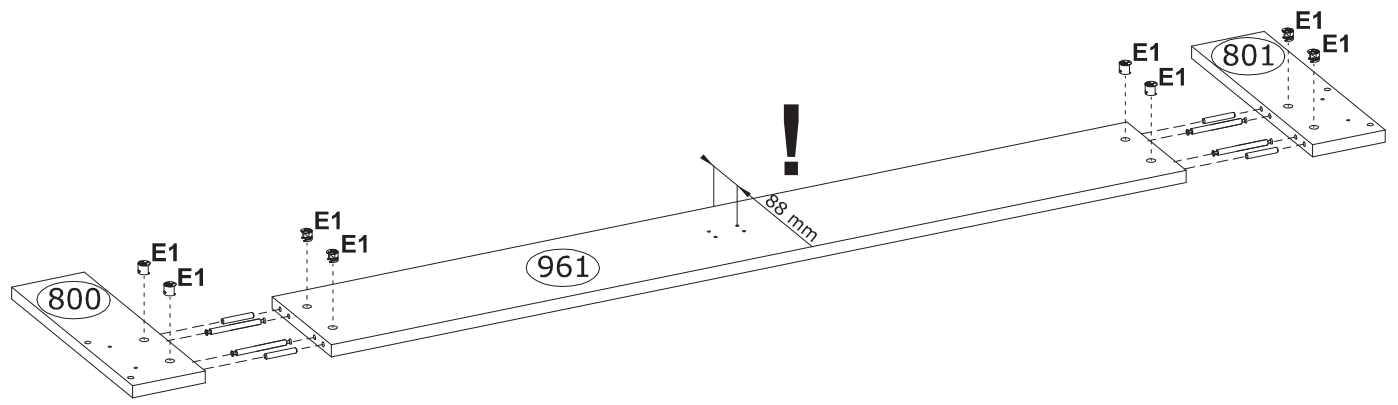
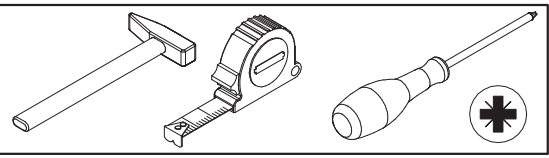
B1 Ø8x50 mm  x4 3991	D Ø6,5x59 mm  x4 4058	E1 Ø15x17 mm  x8 3997
---	--	--



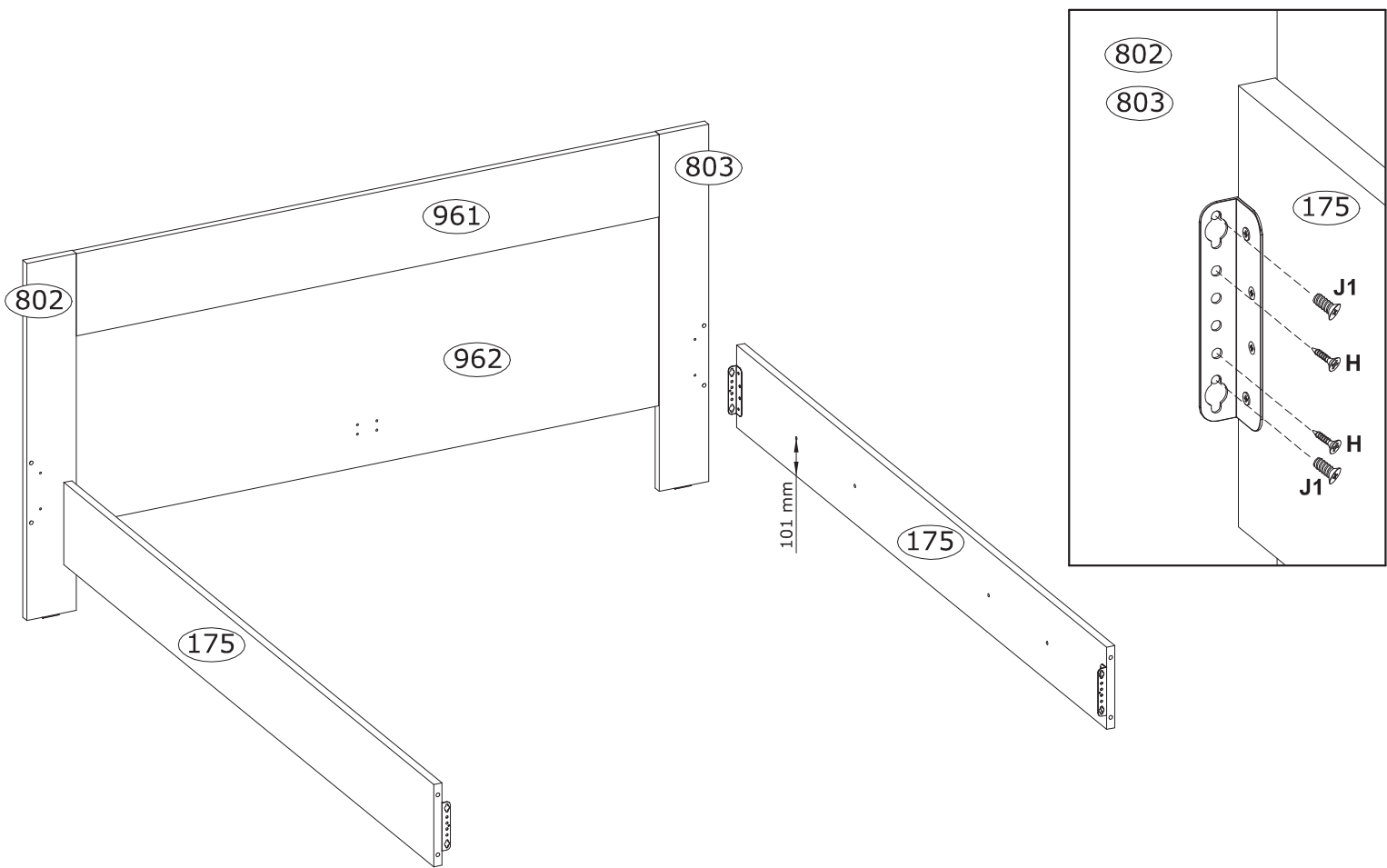
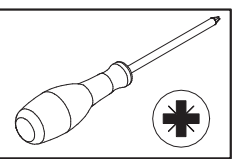

6

H Ø3,5x16 mm  x4 3918	J1 Ø6,0x13 mm  x4 3877
---	--



7

H	Ø3,5x16 mm	J1	Ø6,0x13 mm
	x4 3918		x4 3877

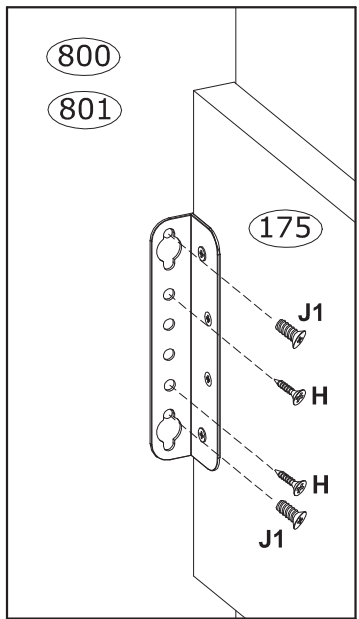
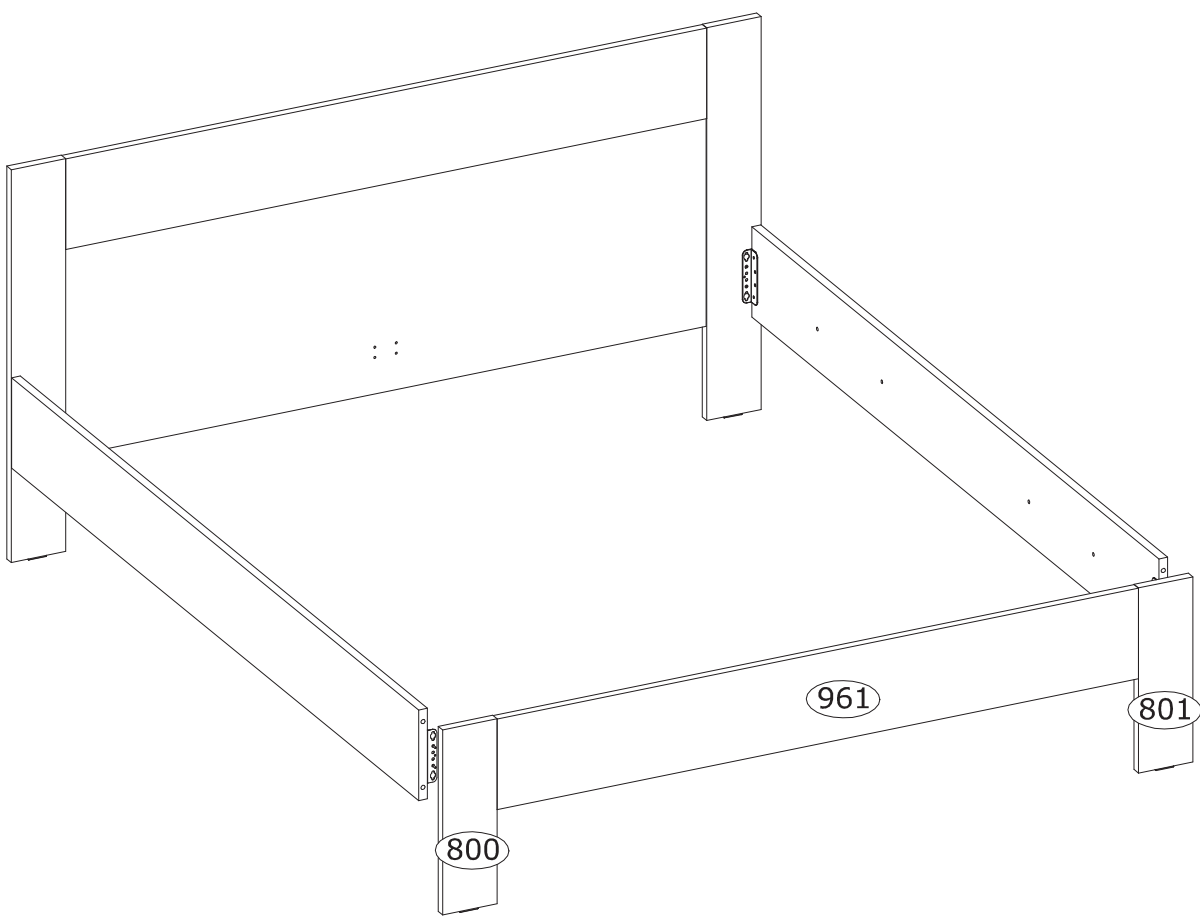
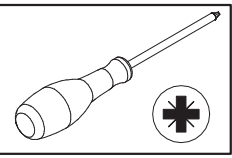

8

M	45x15x5 mm
	x8 90907

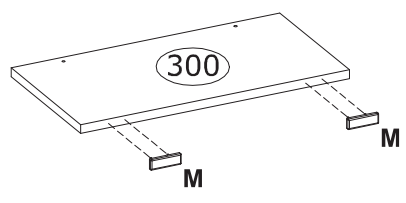
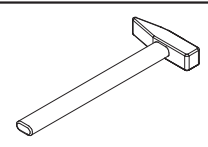

x4

9

G1
Ø4,0x25 mm
x4
3892

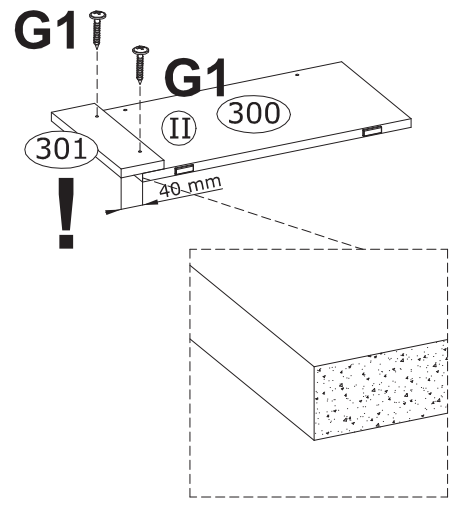
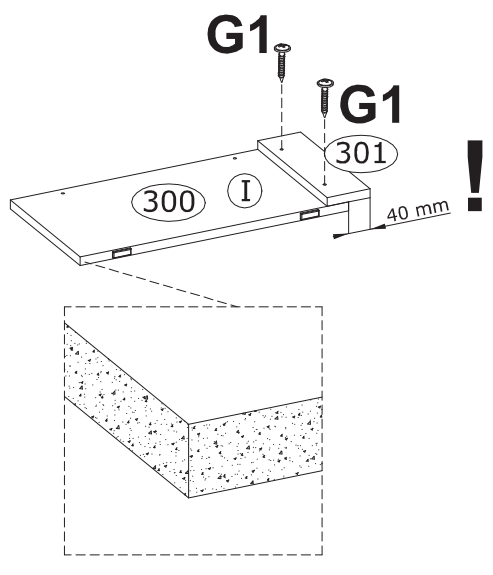
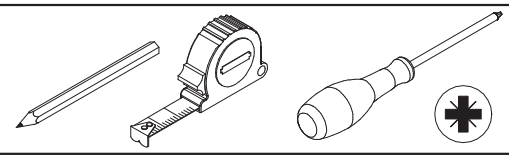

10

G1
Ø4,0x25 mm
x8
3892

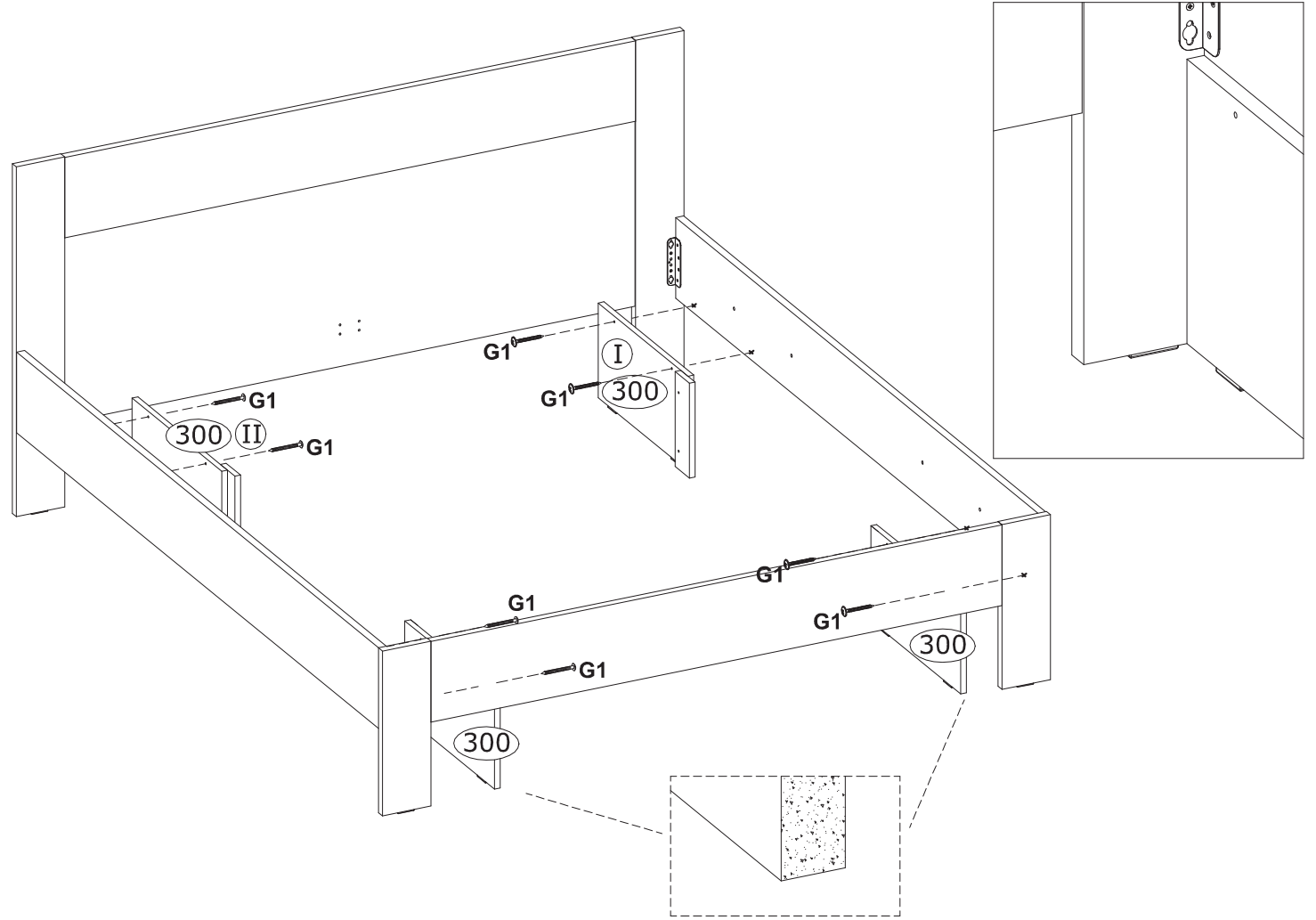
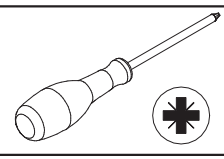

11

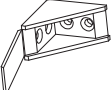
H	Ø3,5x16 mm	N	30x30x18 mm
	x16 3918		x4 79844

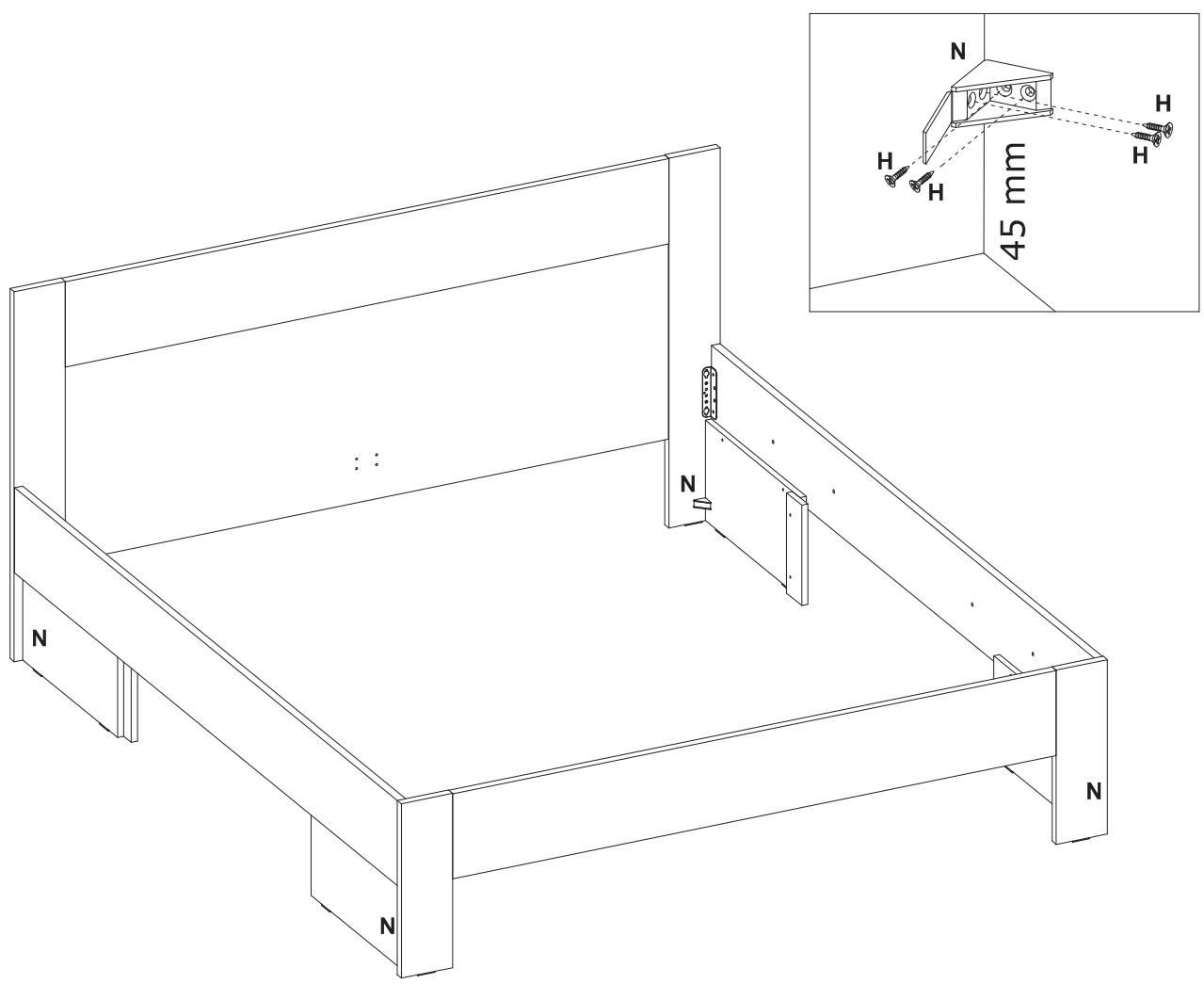
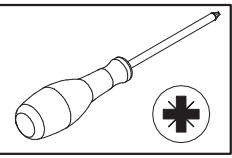

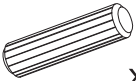

12

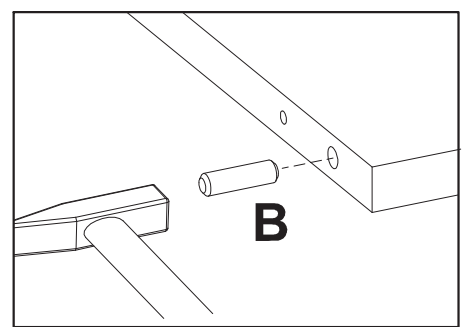
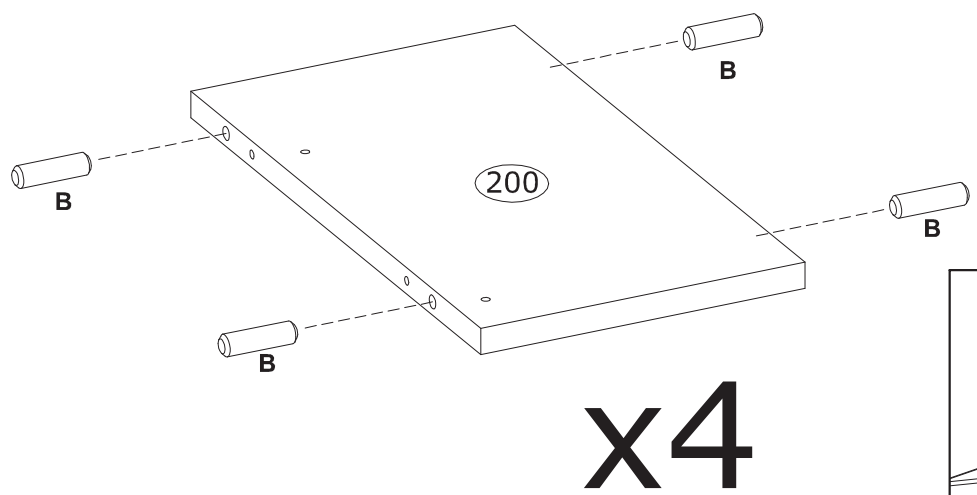
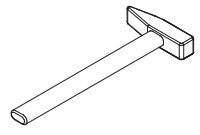
B	Ø8x30 mm
	x16 3989



13

J Ø6,0x8 mm

 x8
 213454

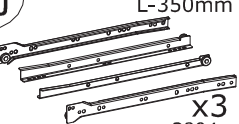
J1 Ø6,0x13 mm

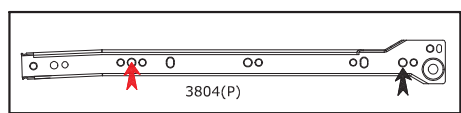
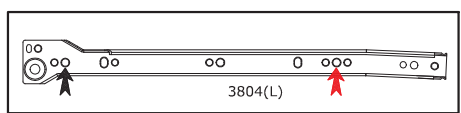
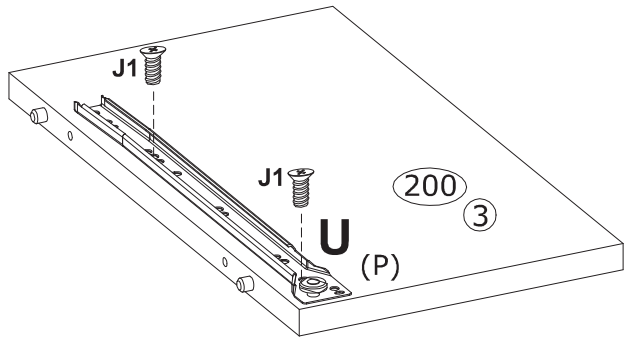
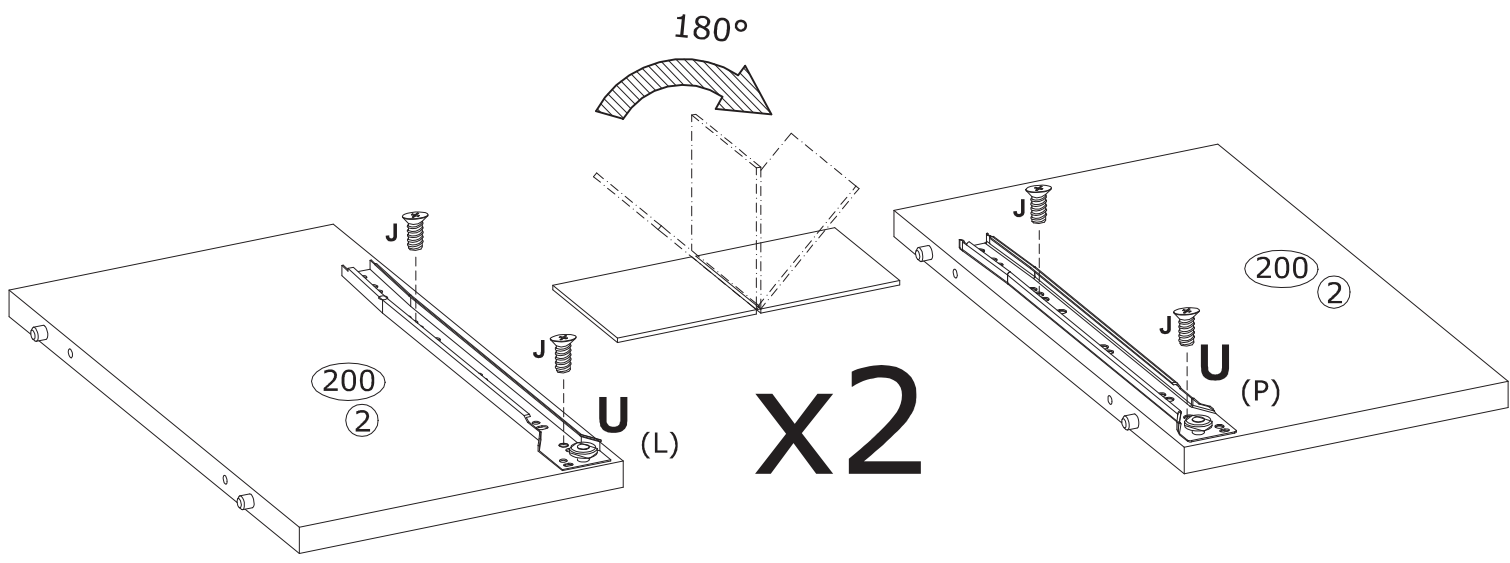
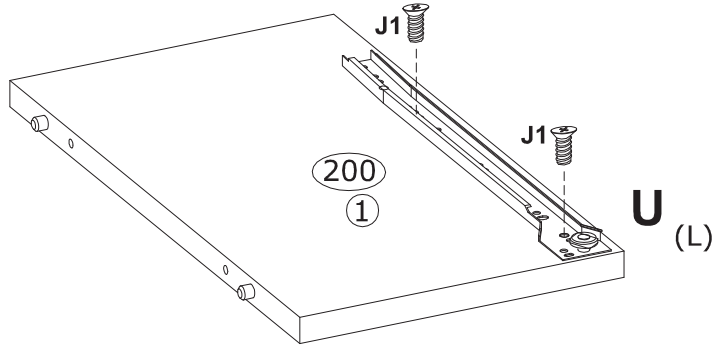
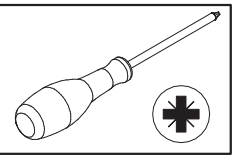
 x4
 3877

U L-350mm

 x3
 3804

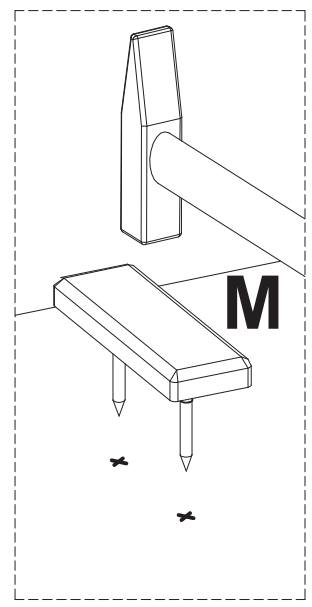
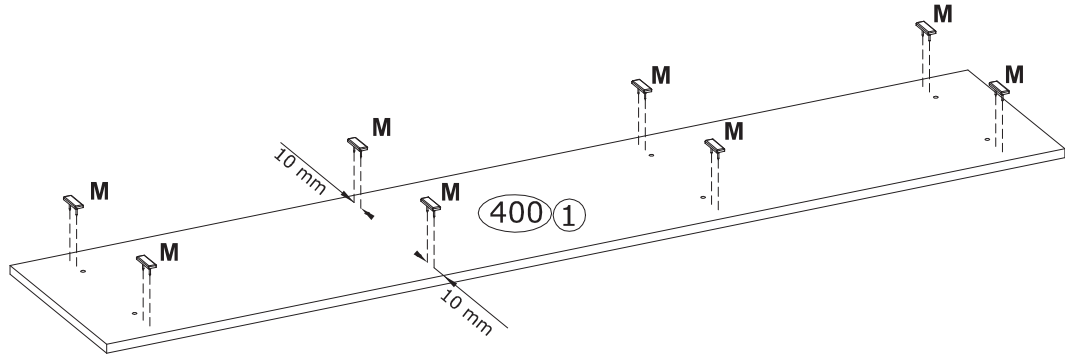
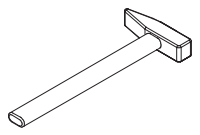

14

M 45x15x5 mm
x8
90907



15

K Ø6,4x50 mm
x8
3884

L 4 mm
x1
3984

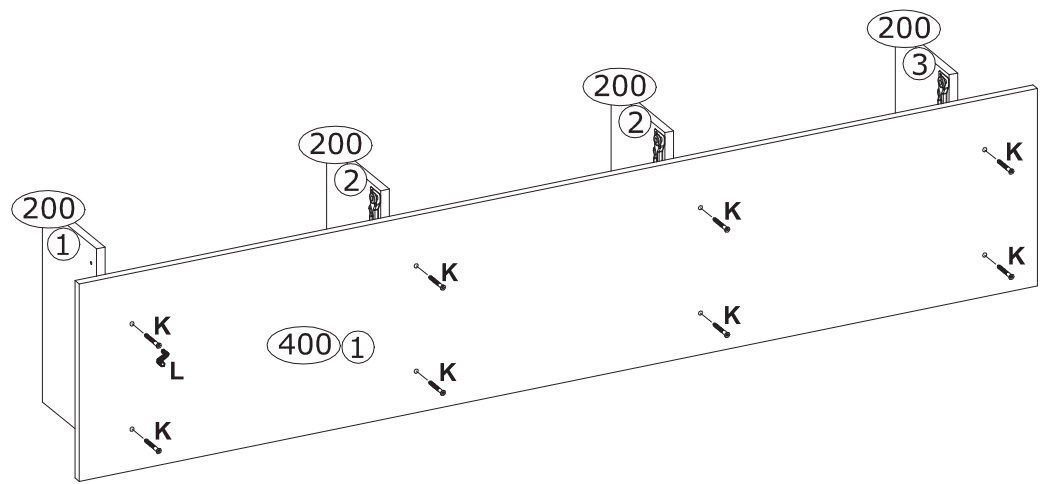

16

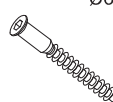
K Ø6,4x50 mm

 x8
 3884

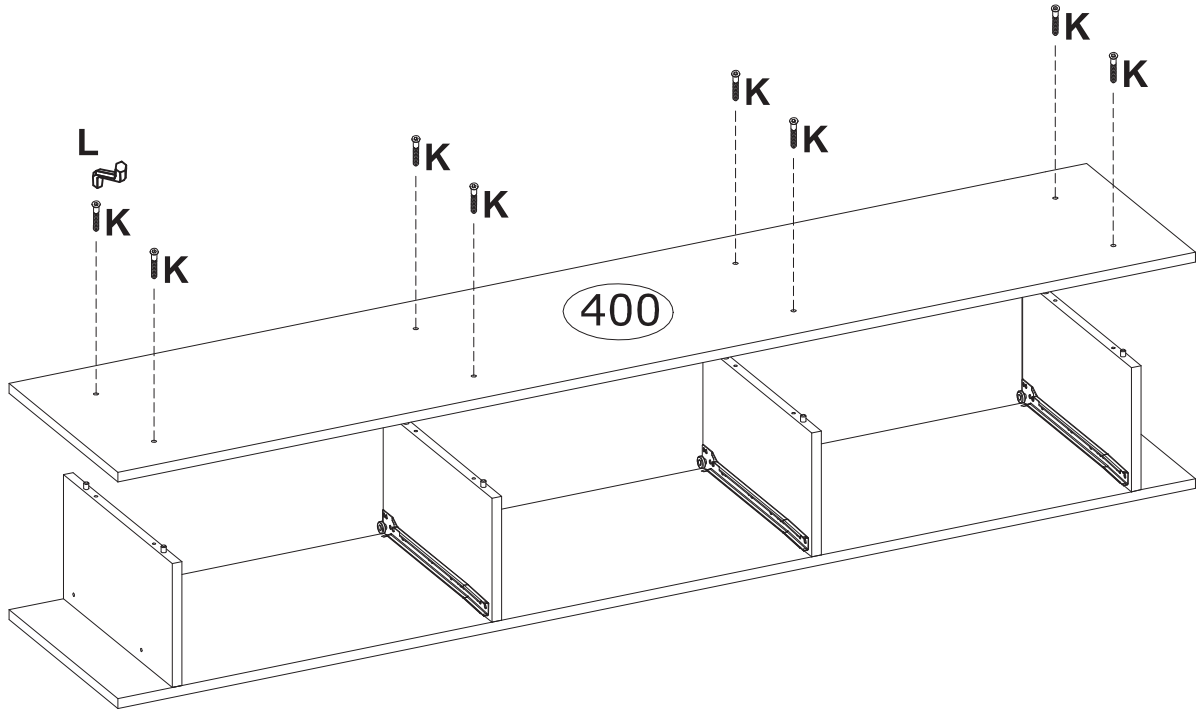
L 4 mm

 x1
 3984

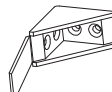

17

H Ø3,5x16 mm

 x16
 3918

N 30x30x18 mm

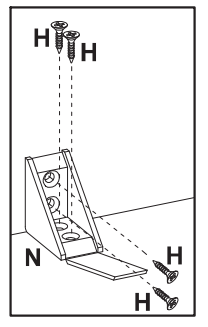
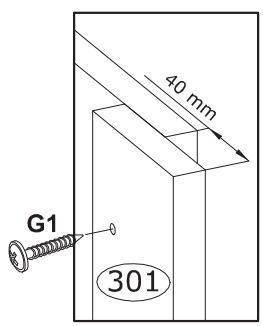
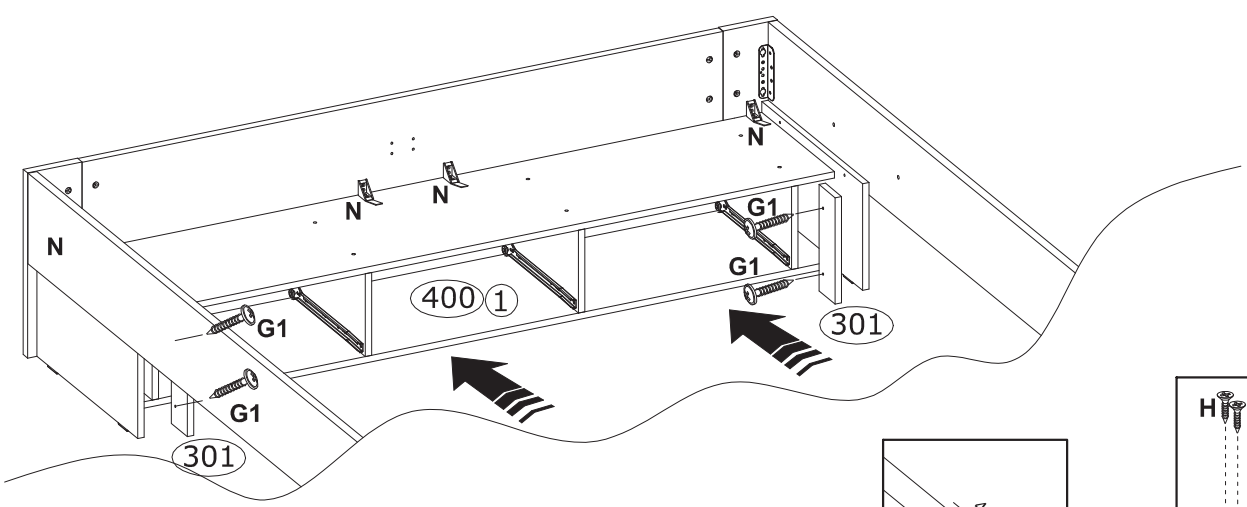
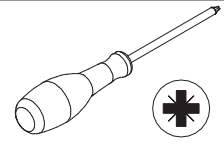
 x4
 79844

G1 Ø4,0x25 mm

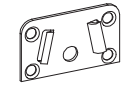
 x4
 3892



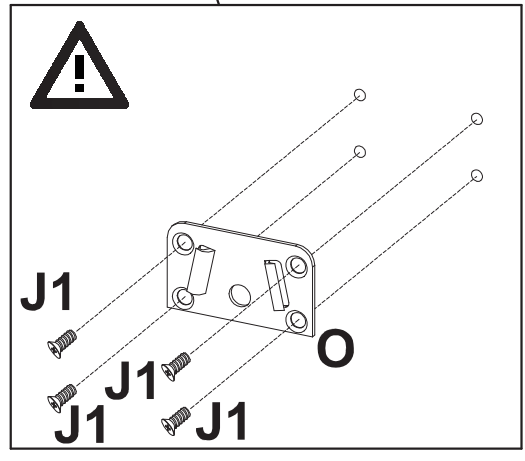
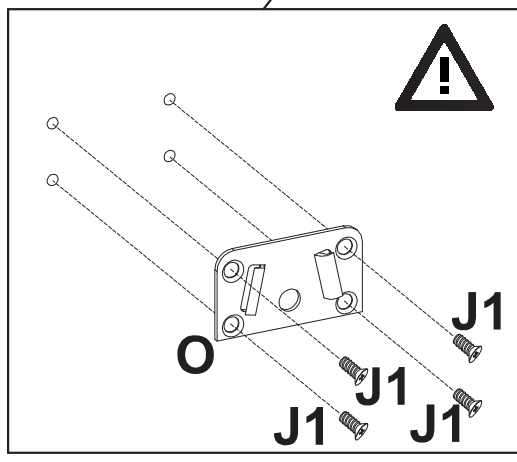
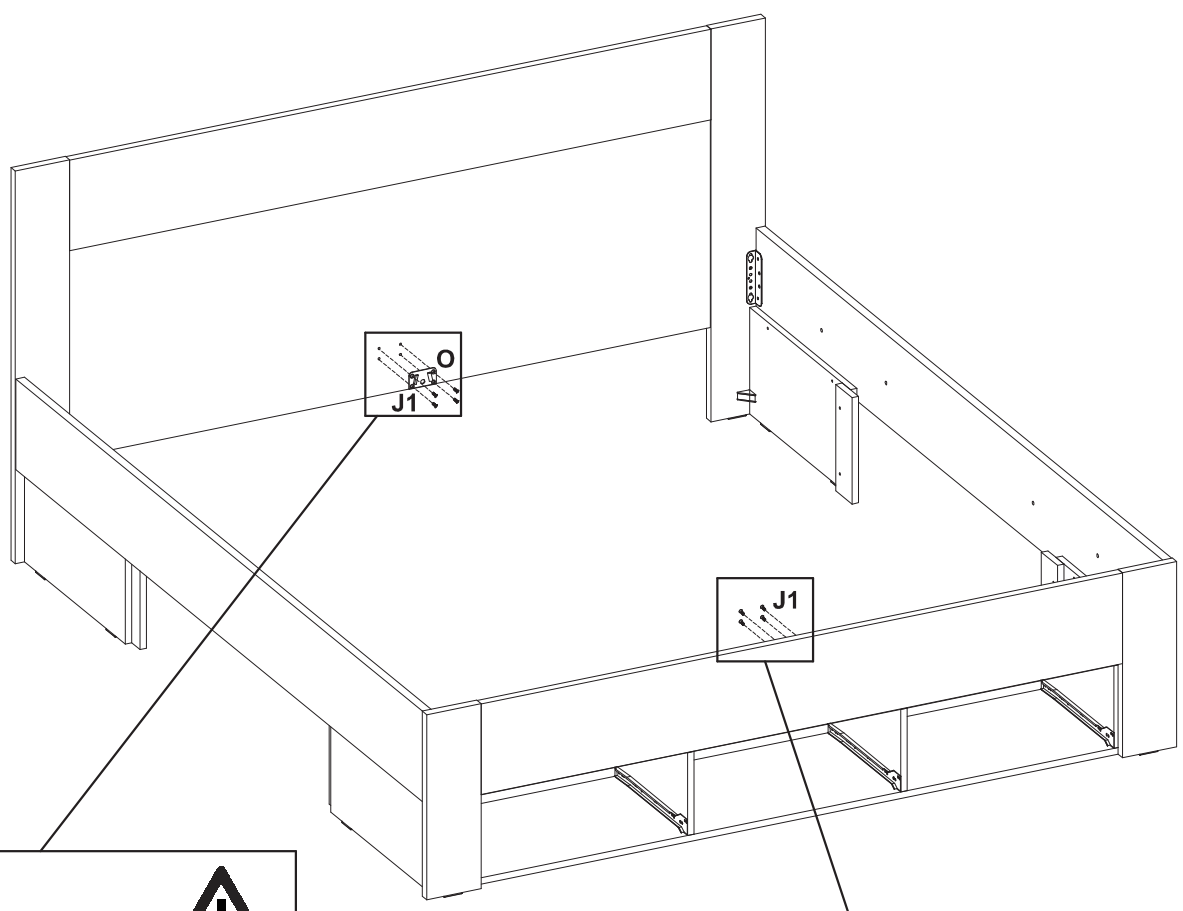
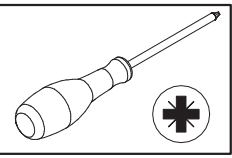

18

J1 Ø6,0x13 mm  x8 3877	O 69x40x7 mm  x2 4009
---	--



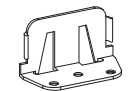

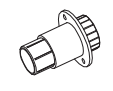
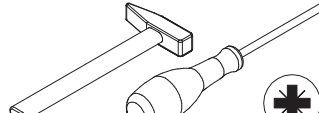
19

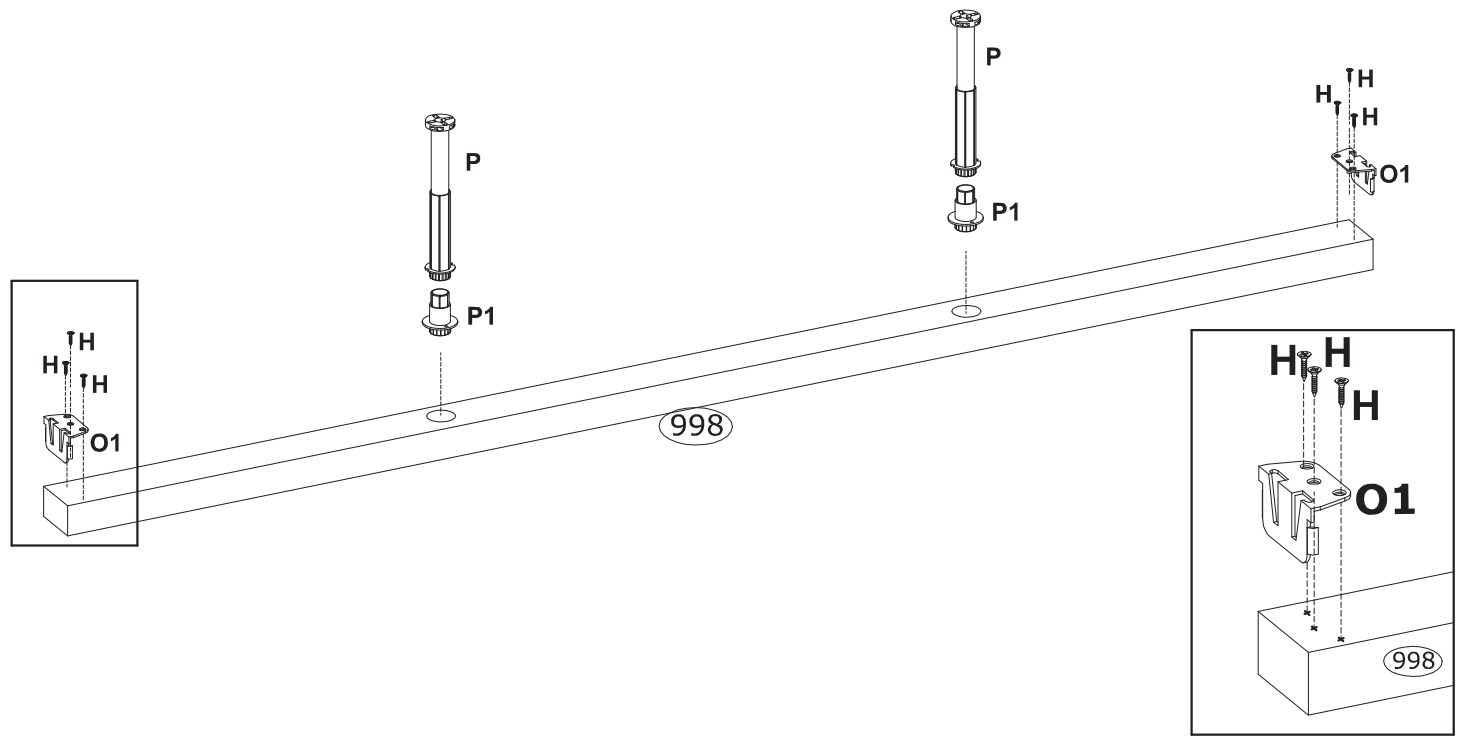
<p>H Ø3,5x16 mm x6 3918</p> 	<p>O1 69x39x32 mm x2 4077</p> 	<p>P L-130/230 mm x2 4012</p> 	<p>P1 L-70 mm x2</p> 	
---	---	---	---	--

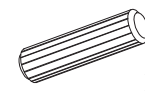

20

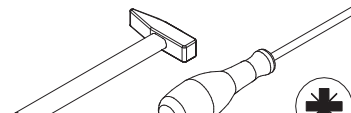
<p>B Ø8x30 mm x8 3989</p> 	<p>G2 Ø4,0x50 mm x12 81980</p> 	
--	---	---

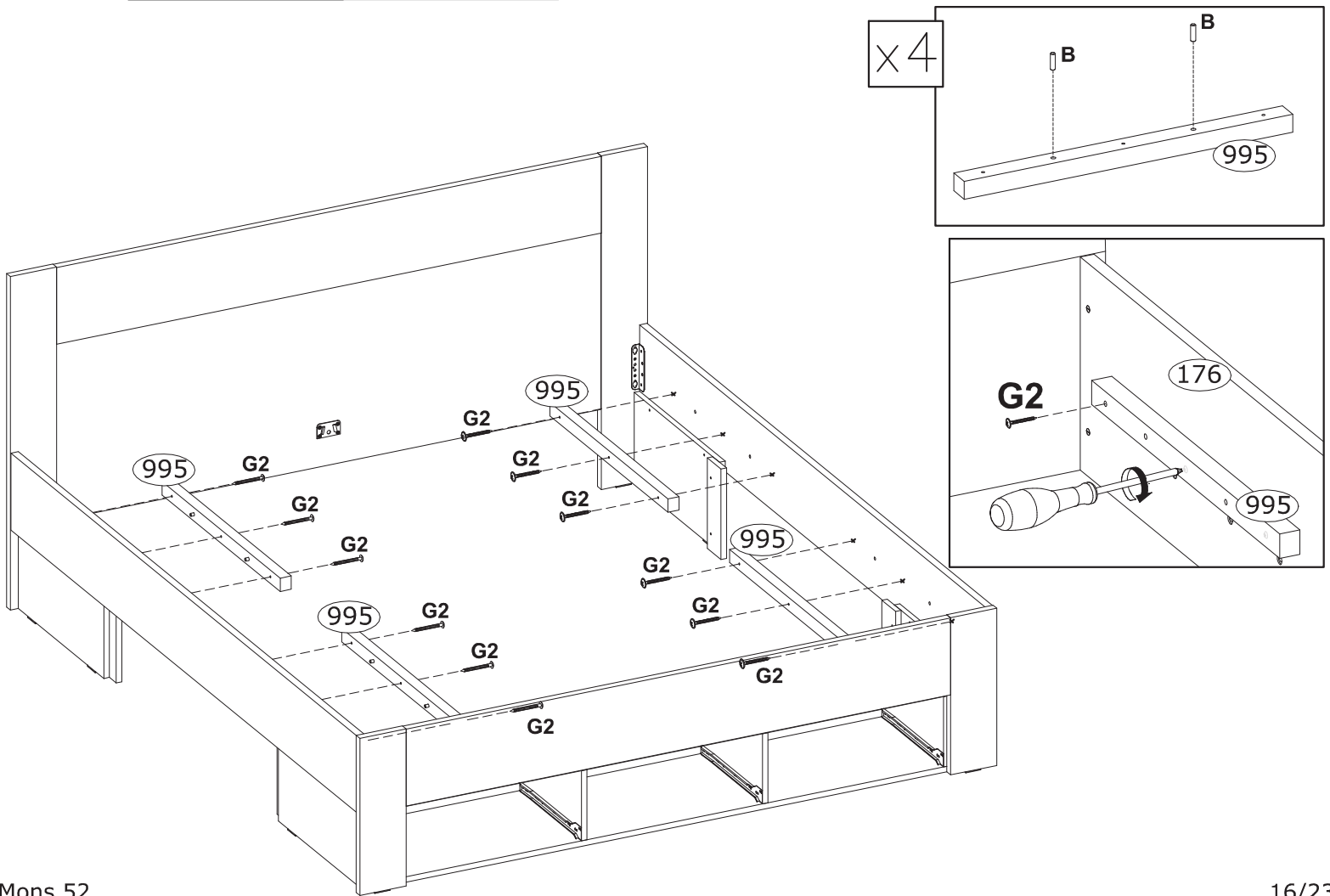

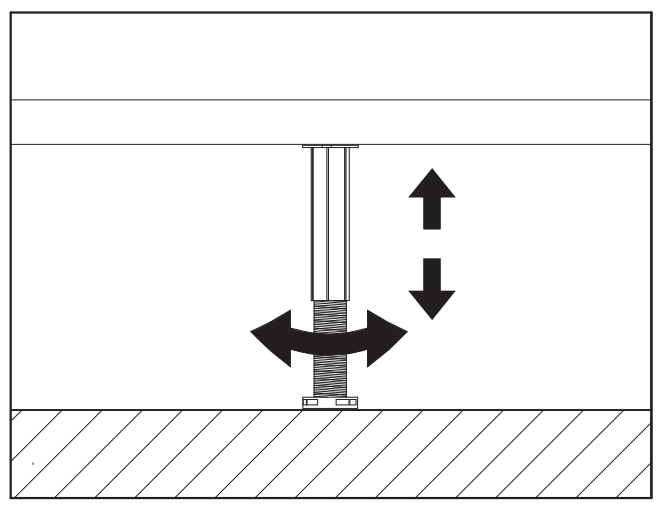
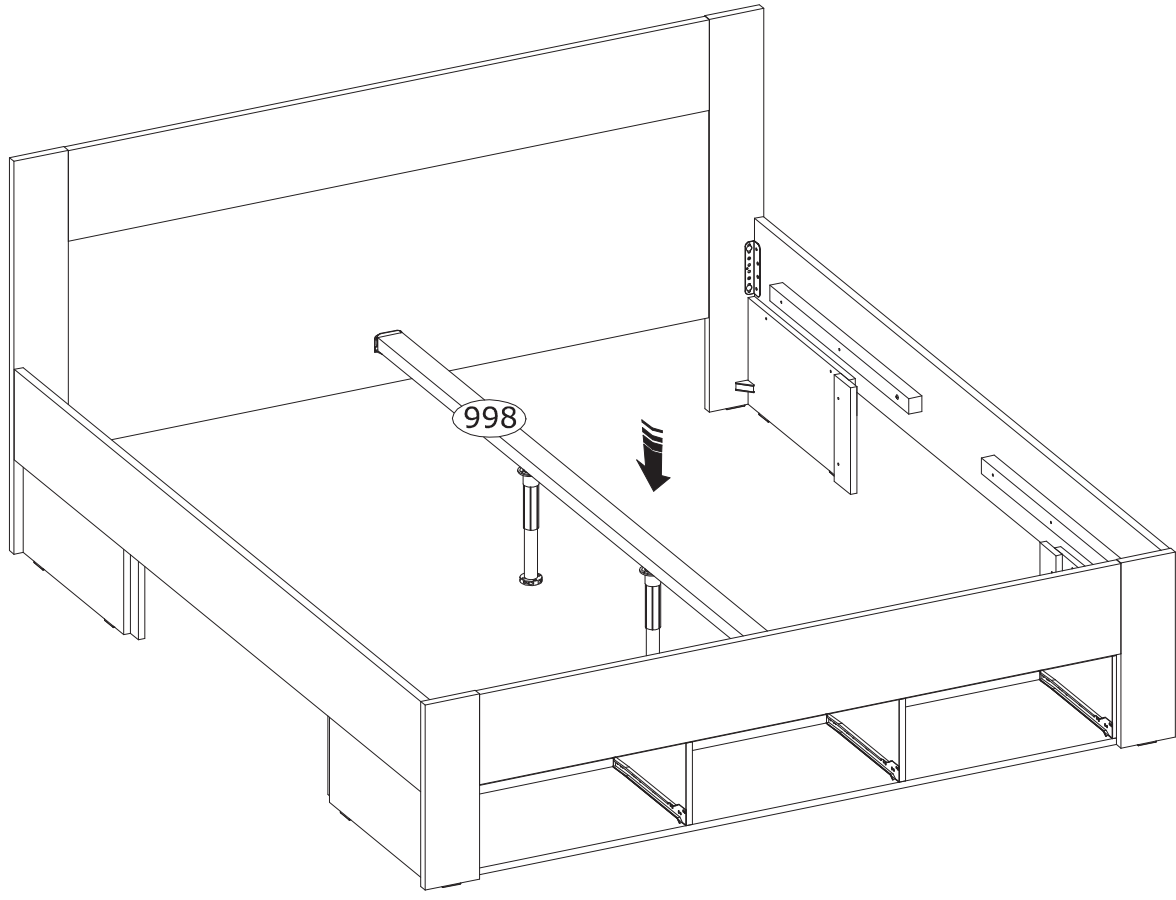
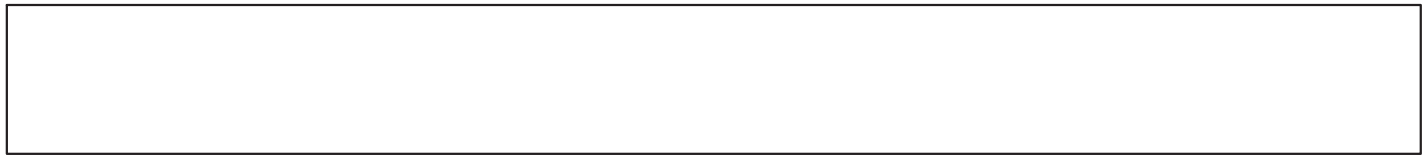

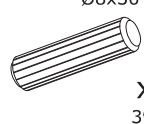
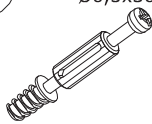

22

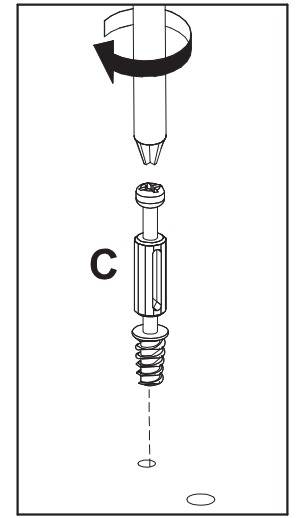
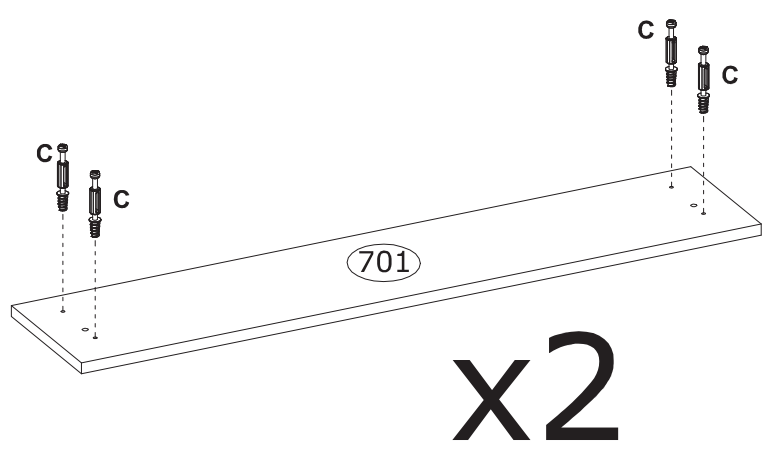
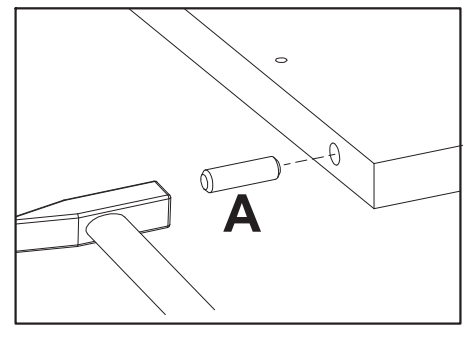
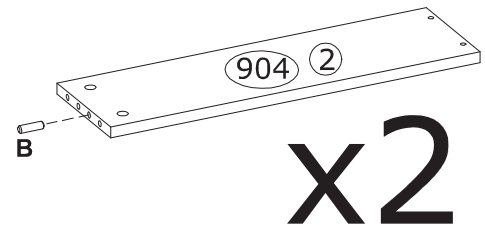
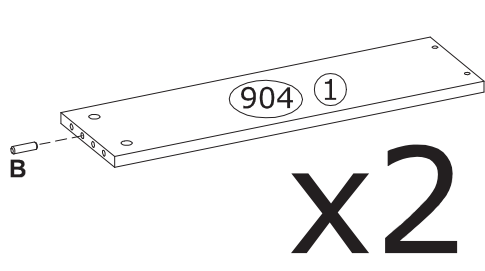
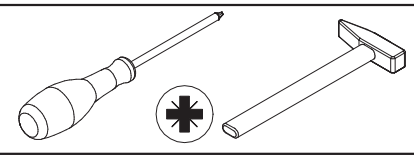
<p>B</p> <p>Ø8x30 mm</p>  <p>x4 3989</p>	<p>C</p> <p>Ø6,5x36,5 mm</p>  <p>x8 4066</p>
---	---

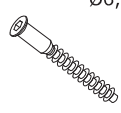

23

<p>K</p> <p>Ø6,4x50 mm</p>  <p>x8 3884</p>
--

<p>L</p> <p>4 mm</p>  <p>x1 3984</p>
--

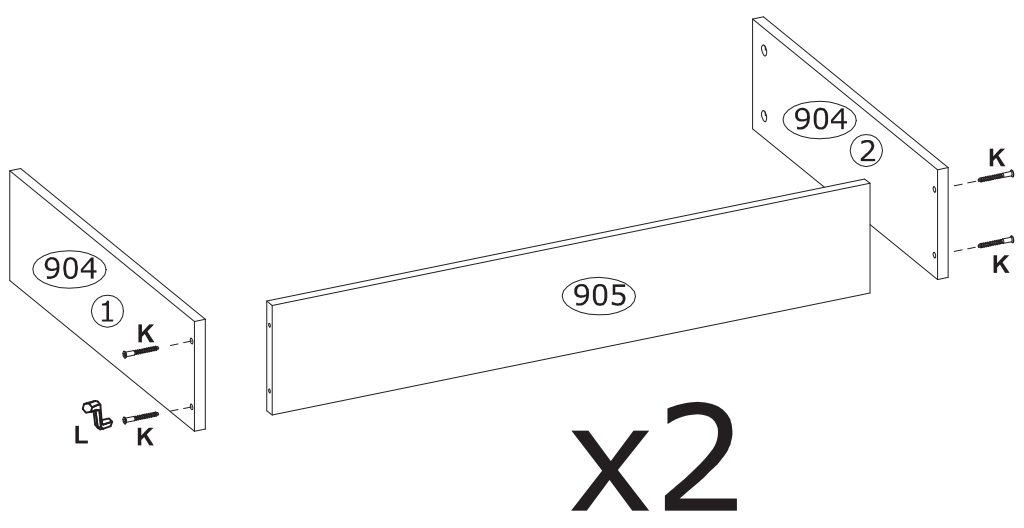

24

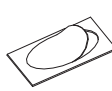
<p>E</p> <p>Ø15x12 mm</p>  <p>x8</p> <p>3996</p>	<p>F</p> <p>Ø20 mm</p>  <p>x8</p> <p>136239</p>
---	--

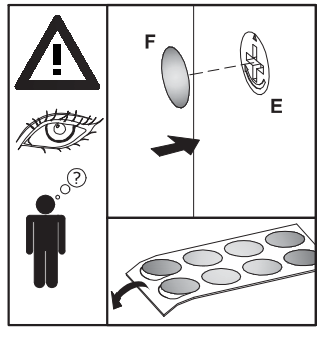
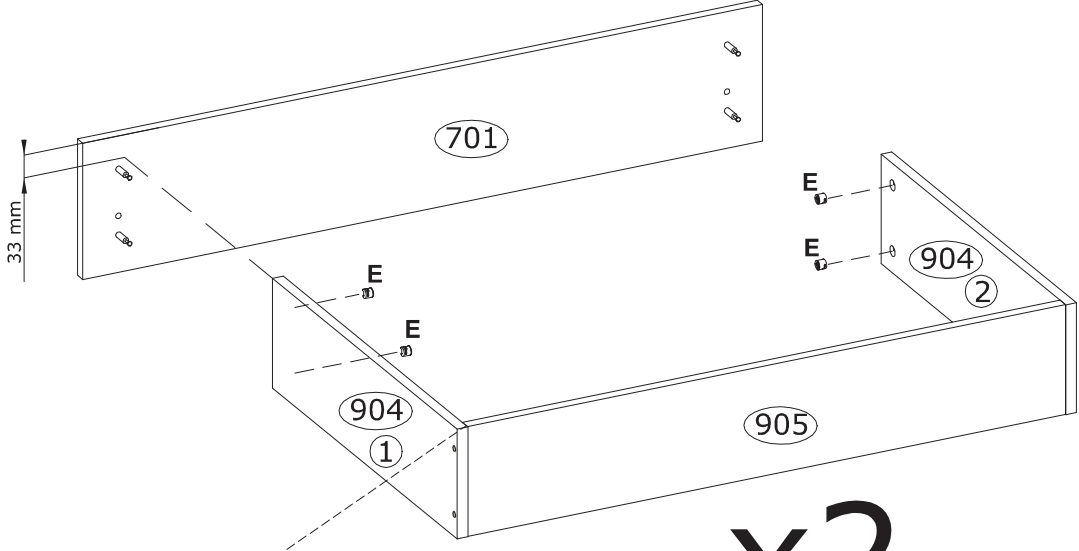
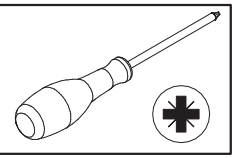

x2

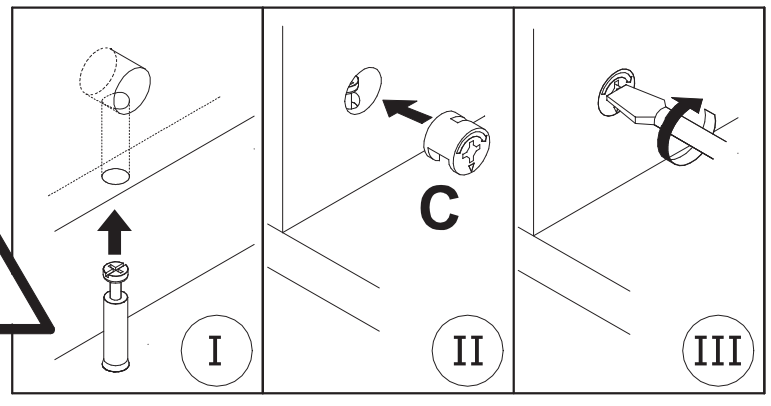
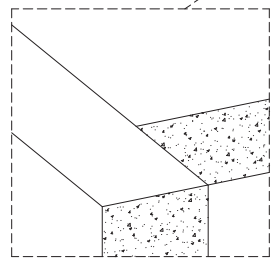

25

<p>G1</p> <p>Ø4,0x25 mm</p>  <p>x28</p> <p>3892</p>

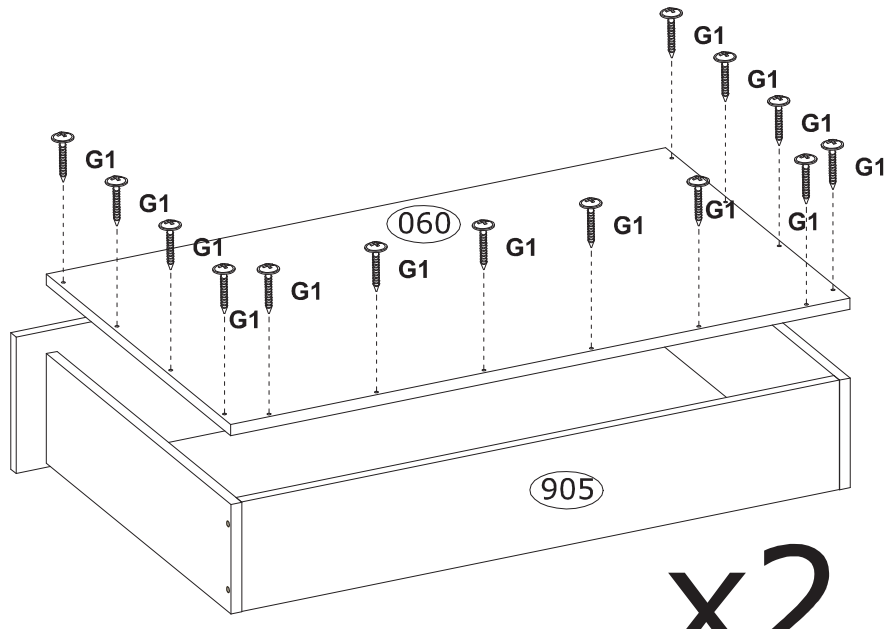
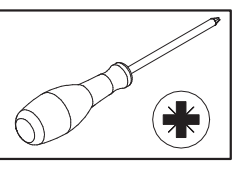

x2

26

H Ø3,5x16 mm x24 3918	T Ø 15 mm x8 3318	N 30x30x18 mm x2 79844
---------------------------------------	-----------------------------------	--

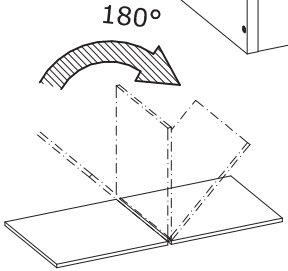
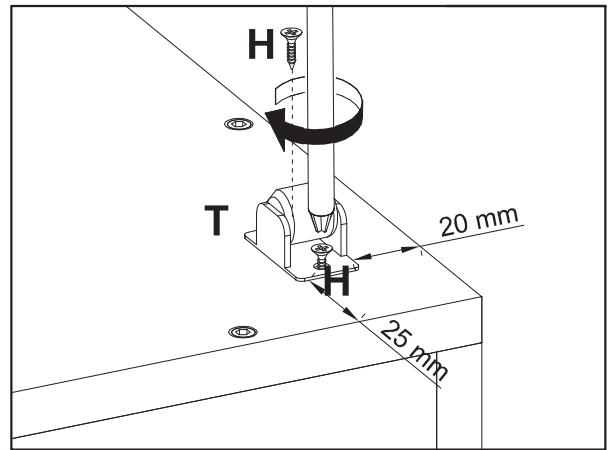
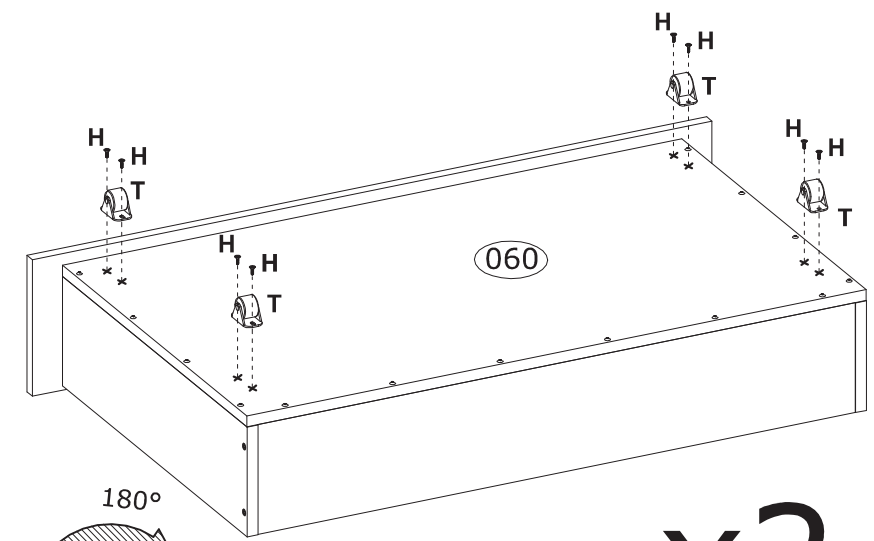
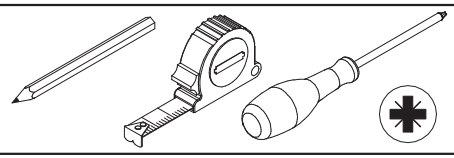

x2

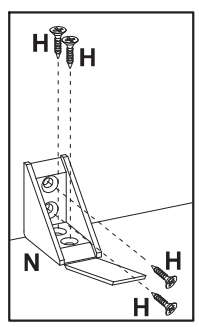
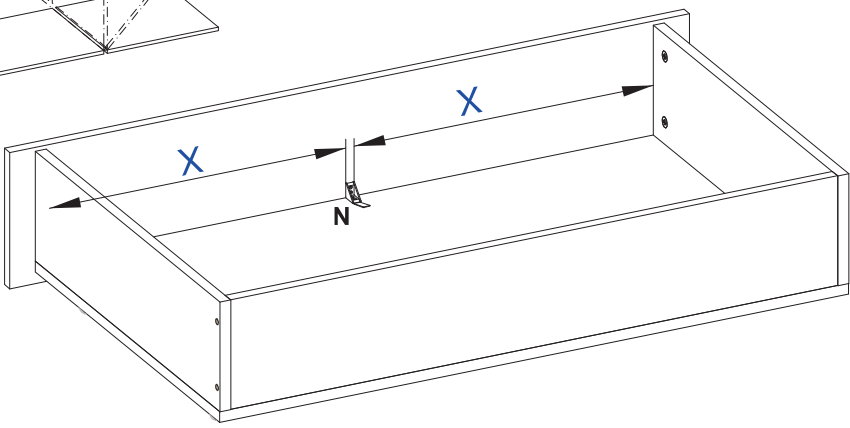

27

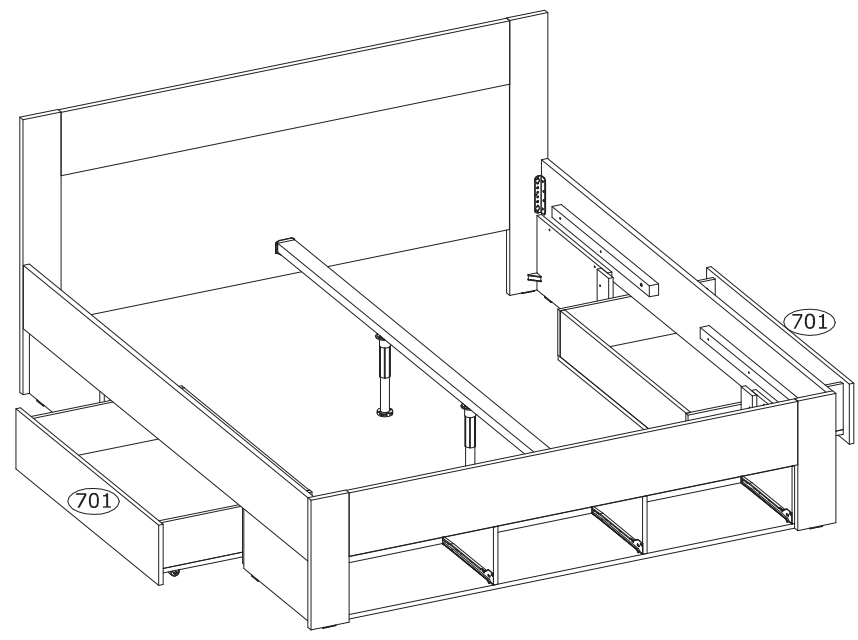

28

B Ø8x30 mm
x6
3989

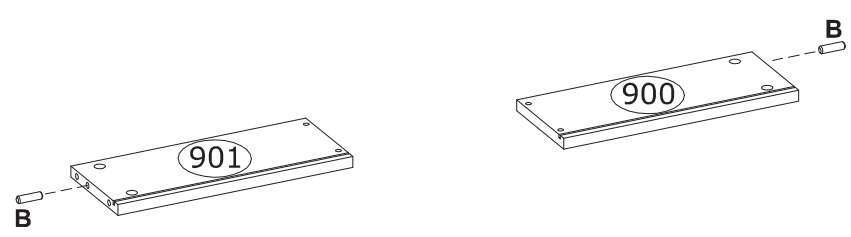
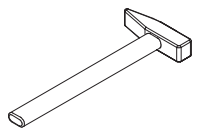

x3

x3

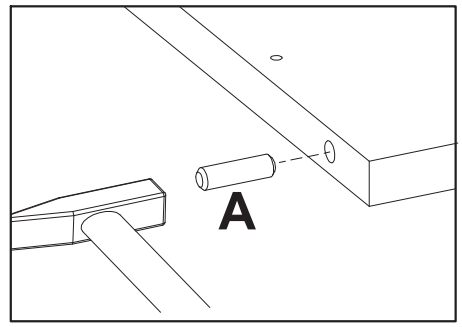

29

C Ø6,5x36,5 mm
x12
4066

G Ø4,0x25 mm
x6
145556

S L-128/D-148 mm
x3
84110

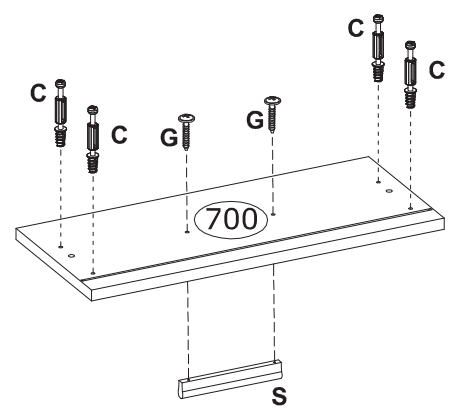
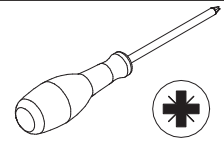

x3

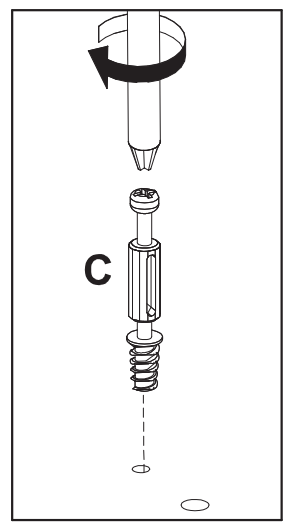

30

K Ø6,4x50 mm
x12
3884

L 4 mm
x1
3984

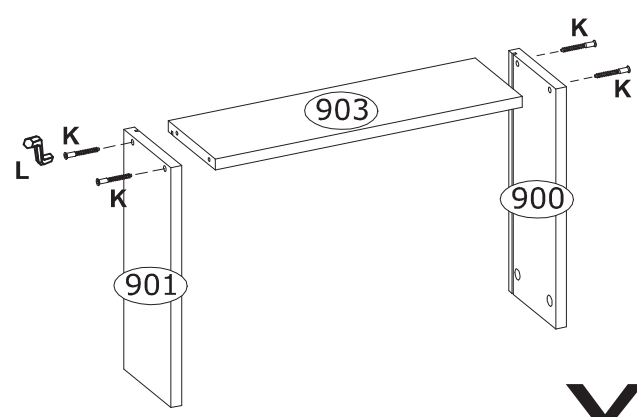

x3

31

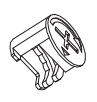
E	Ø15x12 mm
	x12 3996

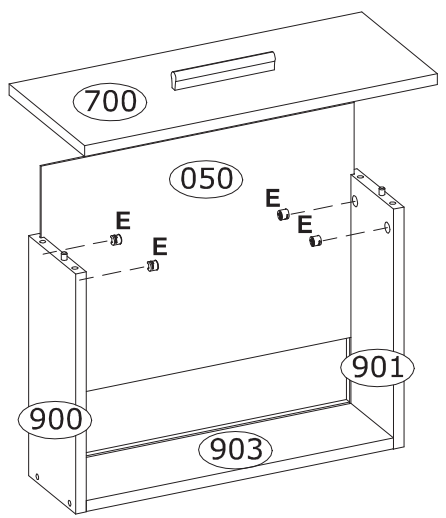
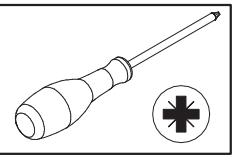

x3

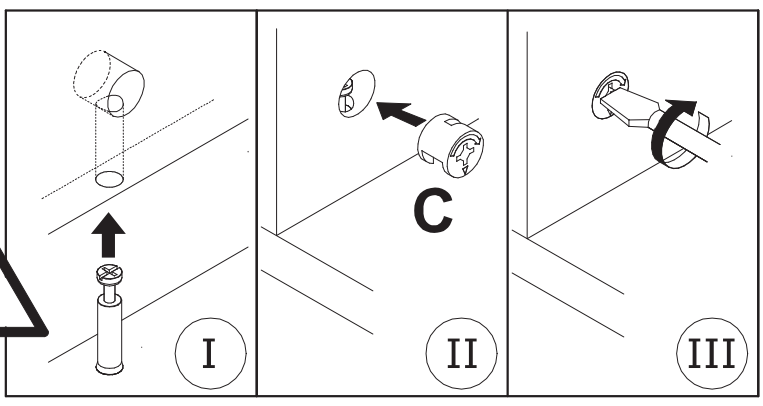

32

H	Ø3,5x16 mm
	x12 3918

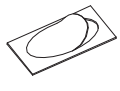
F	Ø20 mm
	x12 136239

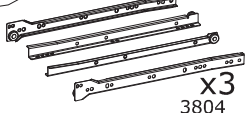
U	L-350mm
	x3 3804

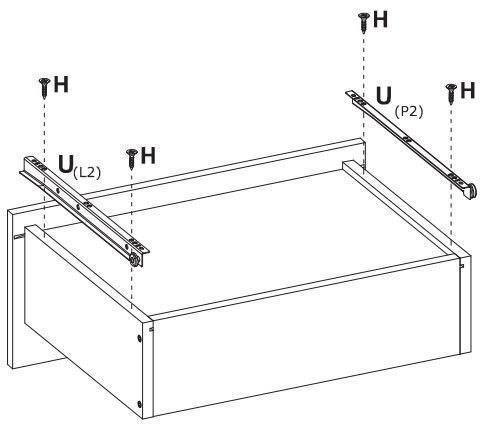
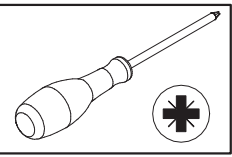

x3

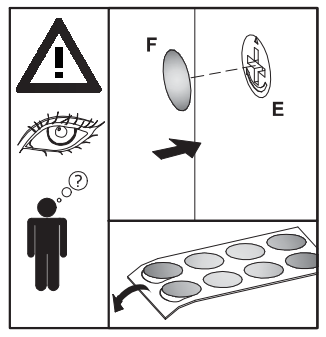

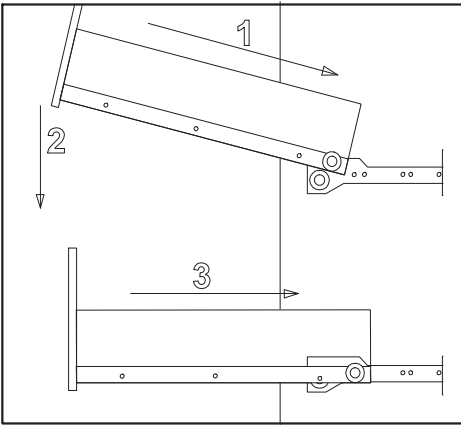
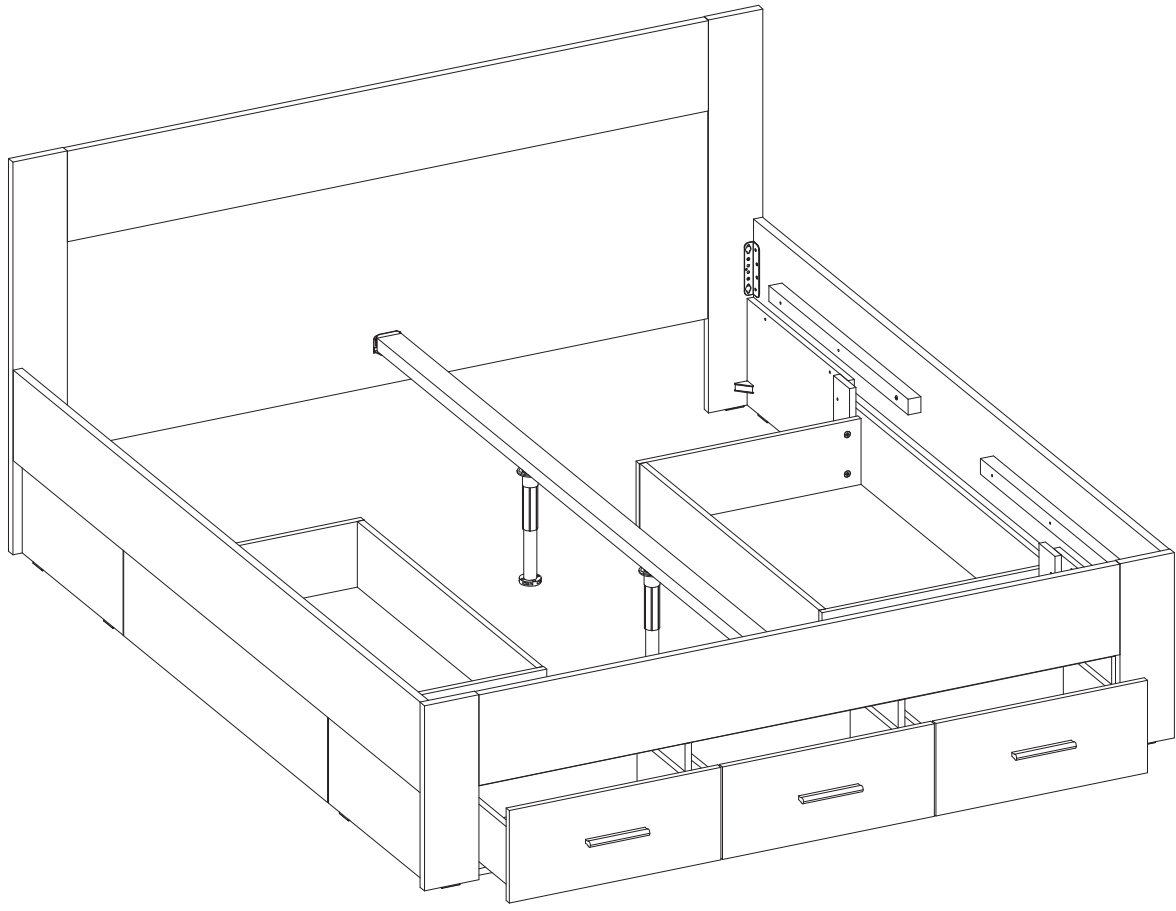
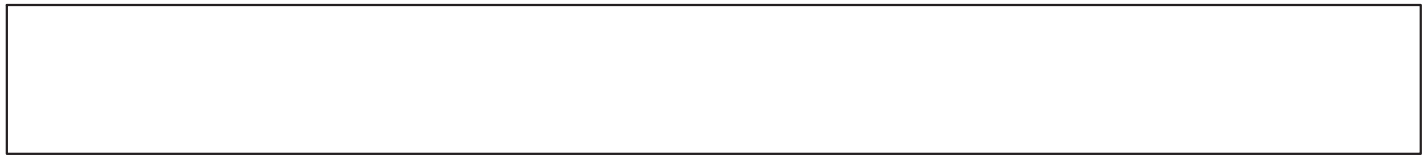

- D** Sicherheits- und Pflegehinweise
- FR** Conseils de sécurité et d'entretien
- NL** Veiligheids- en onderhoudstips
- CZ** Tipy pro bezpečnost a údržbu
- HU** Biztonsági és karbantartási tanácsok
- TR** Güvenlik ve bakım ipuçları
- ES** Instruções de segurança e manutenção
- SRB** Савети за безбедност и одржавање
- SL** Nasveti za varnost in vzdrževanje
- LV** Drošības un apkopes padomi
- BA** Savjeti za sigurnost i održavanje

- GB** Safety and maintenance tips
- IT** Consigli per la sicurezza e la manutenzione
- PL** Wskazówki dotyczące bezpieczeństwa i konserwacji
- SK** Tipy na bezpečnosť a údržbu
- RO** Sfaturi de siguranță și întreținere
- RU** Советы по безопасности и обслуживанию
- PT** Instruções de segurança e manutenção
- HR** Savjeti za sigurnost i održavanje
- LT** Saugos ir priežiūros patarimai
- EE** Ohutus- ja hooldusnõuanded
- BG** Съвети за безопасност и поддръжка

